



PRE / MAIN AMPLIFIER

MODEL **AU-70**



SANSUI ELECTRIC CO., LTD

SANSUI
stereophonic
PRE / MAIN
AMPLIFIER
model AU-70

This amplifier has a maximum output of 50 watts (25W-25W) and features an amazingly low distortion factor of not more than 0.15% at 20 W. A high-quality amplifier with many exciting features, it is delivered to you with Sansui's fullest confidence. Read this instruction manual carefully before you use the amplifier for the first time.

FEATURES

7189 P.P. produces 40W without distortion (Max. 0.95% at 30 cps and 0.15% at 1,000 cps)

The 7189 power tubes operate in class AB₁P.P. (fixed bias) for high-fidelity reproduction. Their combined maximum output is limited to 50 W. The amplifier incorporates a multiplex feedback circuit (total negative feedback: 26 db) for the first time in this class of amplifiers in Japan. This makes it extremely low in distortion over the whole frequency range. Total harmonic distortion at 1 kc is 0.15%. At 30 cps, a very low frequency at which it is extremely difficult to minimize harmonic distortion, the distortion is limited to not more than 0.95%. This is quite a feat for a 50-watt amplifier. Another remarkable feature is the damping factor of 18, a figure which is lower than that of triode power tubes coupled in P.P. This is why bass sounds come out with such clarity.

NFB used in all amplifier circuits, from preamp to power amplifier

The low distortion of the power amplifier is meaningless if the preamp generates distortions. Your AU-70 amplifier uses a three-stage amplifier circuit in its intermediate or control amplifier—unlike conventional one-stage control amplifiers—and has all its circuits in a single negative-feedback loop. These make your AU-70 amplifier free from noise and distortion.

Super-precision transistor preamplifier eliminates hum and noise

The exclusive Sansui four-transistor preamplifier, which features a transistor circuit factor of 4—as compared with conventional 5-10—and a transistor noise factor of 2 db—as compared with conventional 5 db, eliminates hum and noise, the enemy of high-fidelity reproduction. The amplifier has a much better S/N ratio and a gain three times larger than vacuum-tube amplifiers.

Each channel can be operated independently. Equipped with tone defeat).

Each channel has independent tone controls for bass and treble. This makes fine adjustment possible. Moreover, each channel is equipped with tone defeat which cancels the tone control circuit. You can easily obtain a flat frequency response without causing any undulation in response or reduced gain in bass and treble as in the case of conventional mechanical control by means of a tone volume knob. Therefore, you can get an accurate, perfectly flat response from your AU-70 amplifier just by flipping a switch.

Blend circuit permits continuous shift from monaural to stereo

As you turn the "BLEND" switch clockwise, your AU-70 amplifier gradually shifts from monaural to stereophonic reproduction. This feature enables you to get full stereophonic effect by compensating program sources which give a particularly strong effect of the concert hall.

Easy-to-read three-range output level meters

Each output level meter can be switched over to any of the three scales of 5, 10 and 25 watts. The meters not only give direct readings of both channels, but also indicate any lack of balance between the right and left outputs. These prove very useful in balancing the outputs.

Three-dimensional performance possible with the center-channel output terminal

Your AU-70 amplifier has an output terminal for the center-channel amplifier. Connect it to your monaural amplifier—we recommend Sansui Q-15—to produce a three-dimensional effect.

Equipped with advanced, high-performance accessory circuits

Your AU-70 amplifier is equipped with various advanced accessory circuits such as loudness control, low and high filters, tape monitor, tone defeat, presence, blend, speaker switch and headphone jack.

SPECIFICATIONS

Vacuum Tubes, Transistors and Diodes: 7189×4, 6AN8×2, 12AX7×3, OA-91 germanium diode×2, 2SB-381 transistor×4, SD-1B silicon diode×2 and TC. (0. 2) P1 1/3 selenium rectifier×1
Total: 9 tubes and 9 diodes

Main Amplifier:

Maximum Output: 25 W-25 W—50W total
Harmonic Distortion: Max. 0.15% at 20W for 1 kc
Max. 0.95% at 20W for 30 cps
Intermodulation: Max. 0.85% at 20 W, 50 cps + 5.5kc
Frequency Response: ±1 db, 10-80,000 cps
Output Impedance: 8 and 16 ohms

Preamplifier:

Gain

Phono MAG 84 db (Output 20 W at 1.1-mV input)
X-TAL 54 db (Output 20 W at 36mV input)
TAPE 86 db (Output 20 W at 0.9-mV input)
MIC 86 db (Output 20 W at 0.9-mV input)
AUX (TAPE MON) 51 db (Output 20 W at 50-mV input)
TUNER 51 db (Output 20 W at 50-mV input)
S/N ratio 52 db (at TAPE terminal)
Residual noise: Less than 0.25 μ W

Capacitor-resistor Tone Control:

50 cps + 11 to -15 db
10 kc/s + 12 to -13 db

Negative-feedback Equalizer: TAPE: NARTB
PHONO: RIAA

Accessory Circuits:

Presence Control: Turnover at 150 cps
Low Filter: 50 cps—12.5 db
High Filter: 10 kc—13.5 db
Loudness Control
Tone Defeat
Tape Monitor
Headphone Jack
Tape Recorder Playback Connection
Terminal for Center-Channel Amplifier
Level Meter (for output) Three ranges of 5, 10 and 25W
Blend Control

Power consumption: 118 VA

Size: Width 405 mm, Depth 320 mm, Height 142 mm

Weight: 13.7 kg

Power supply: 100, 117 and 240 V, AC 50~60 cps

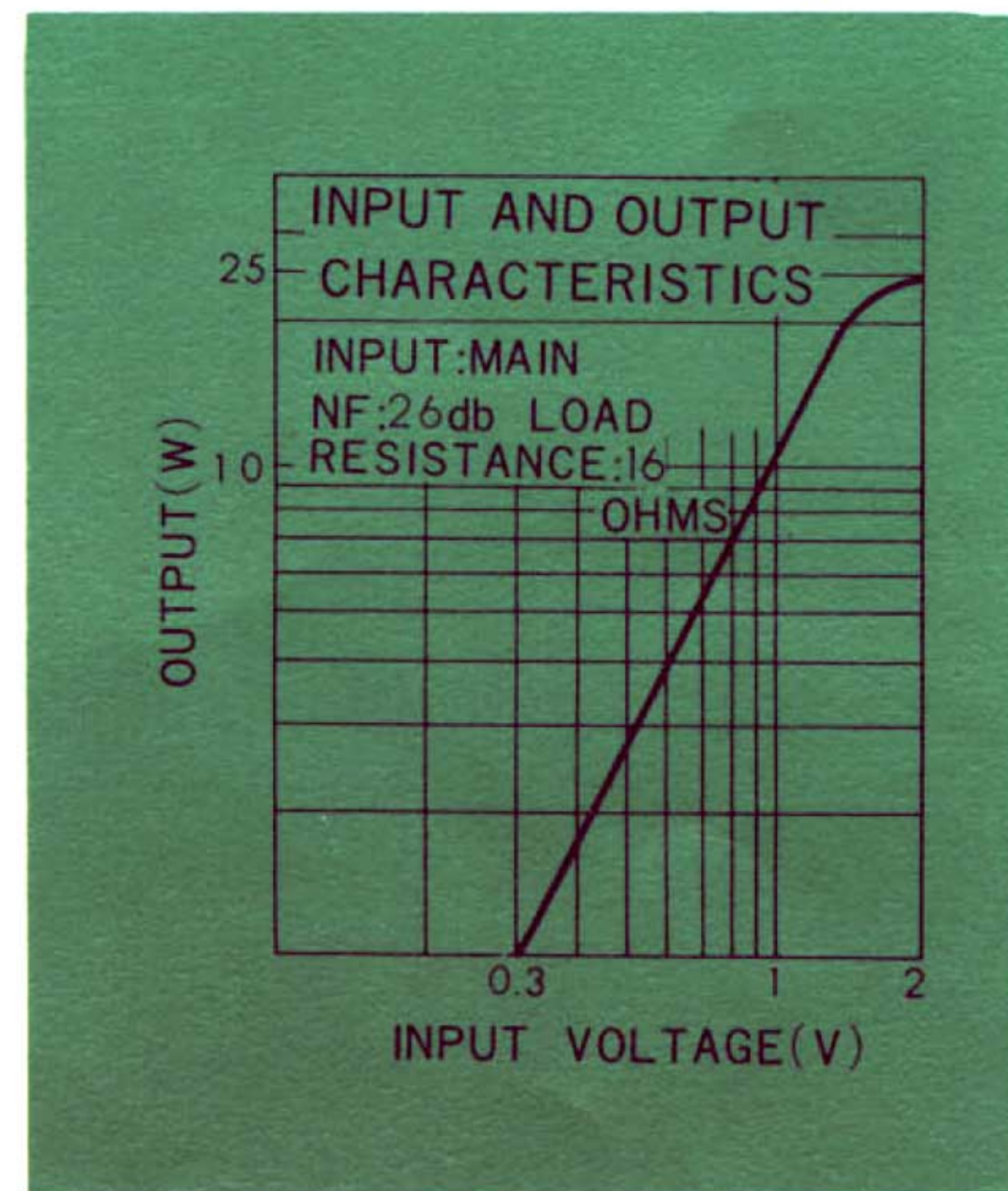
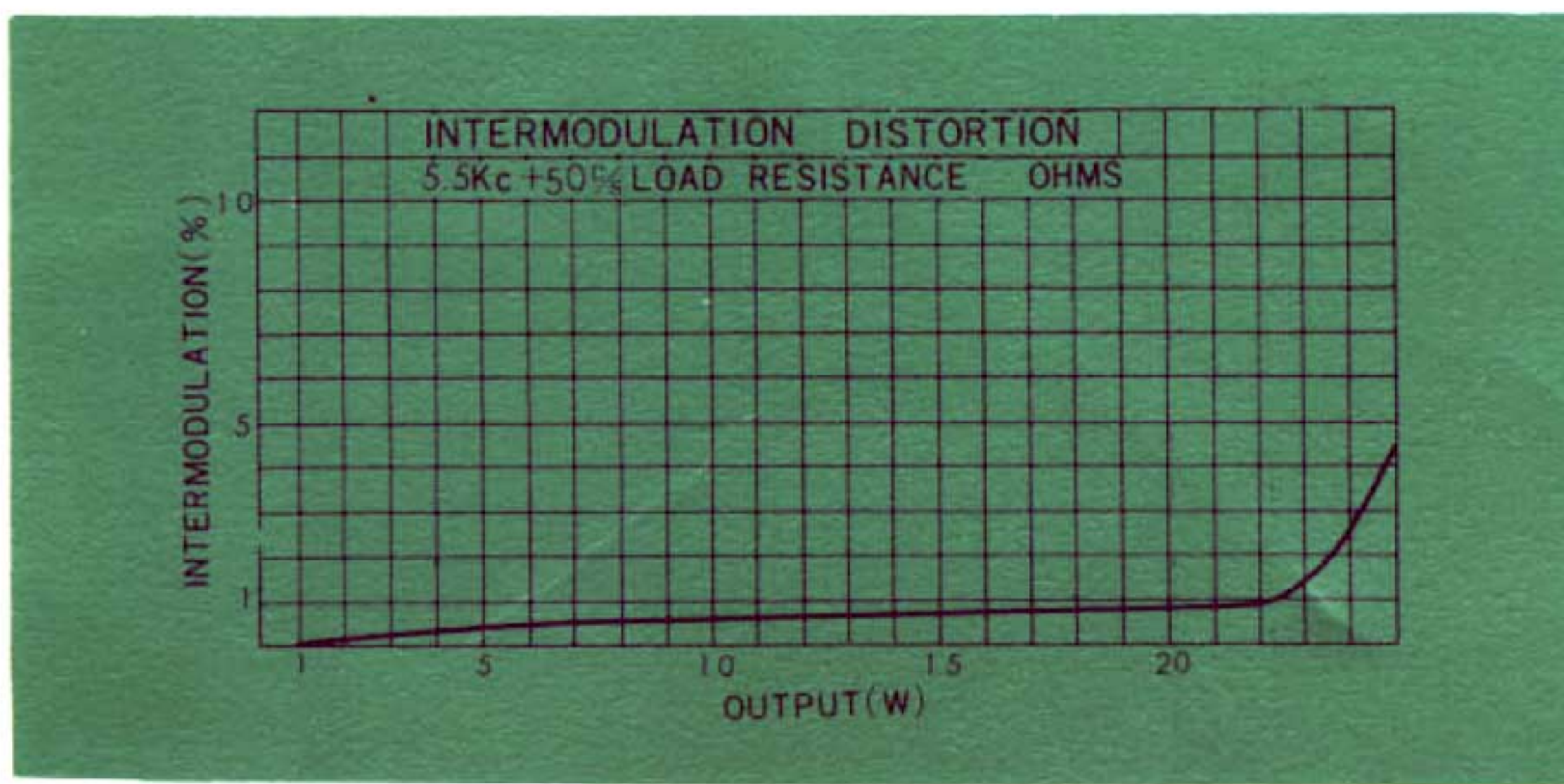
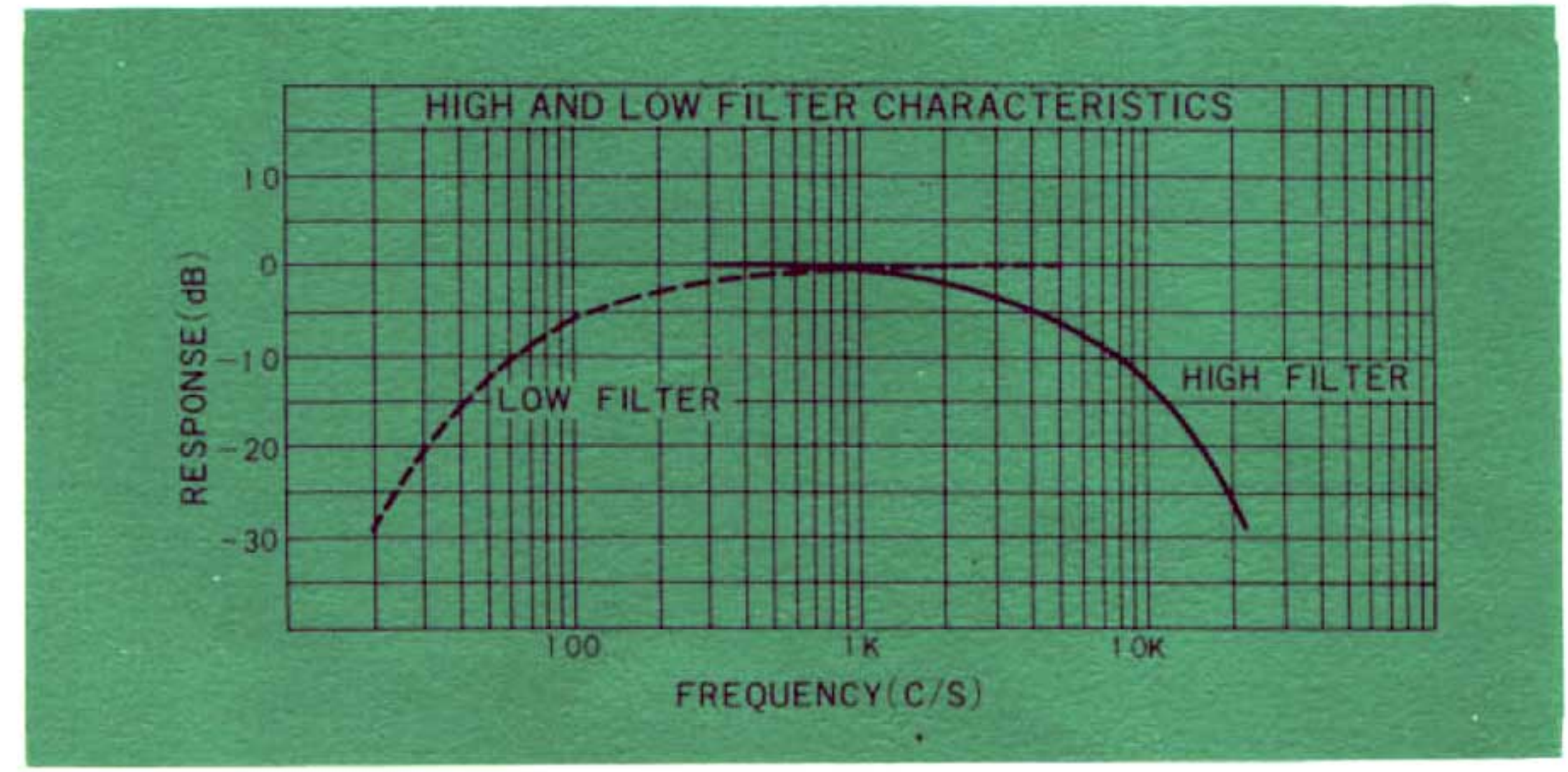
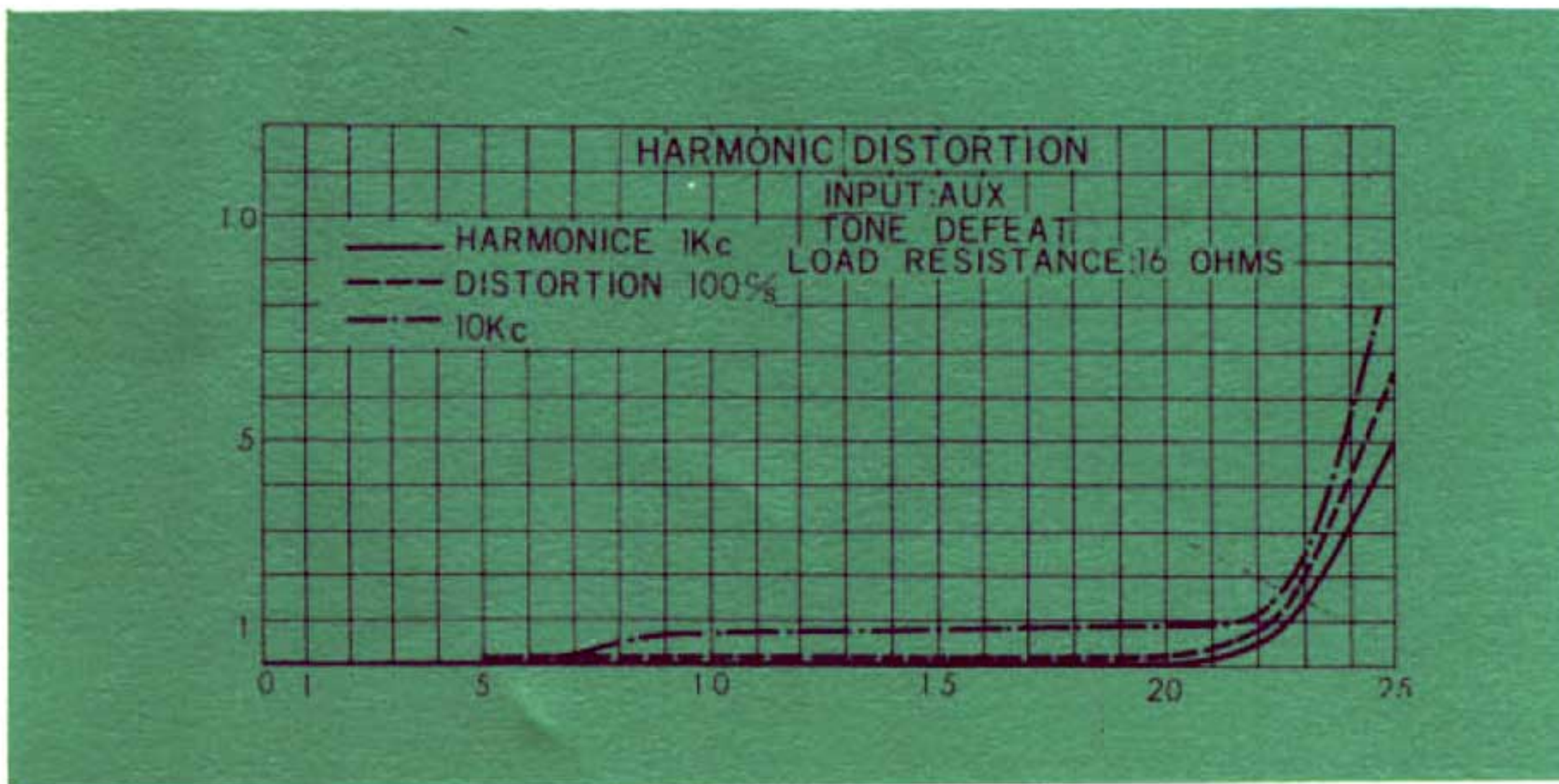
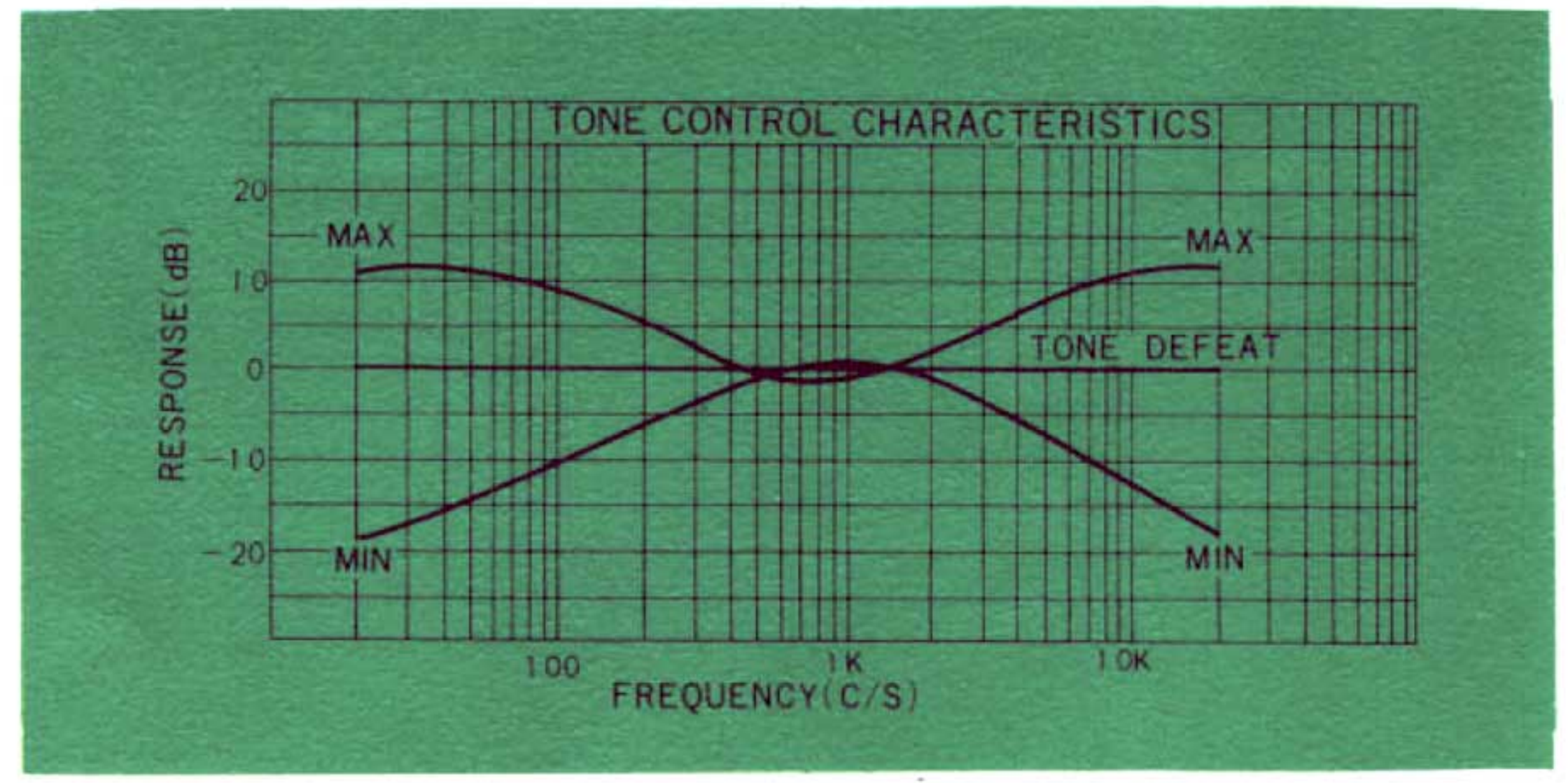
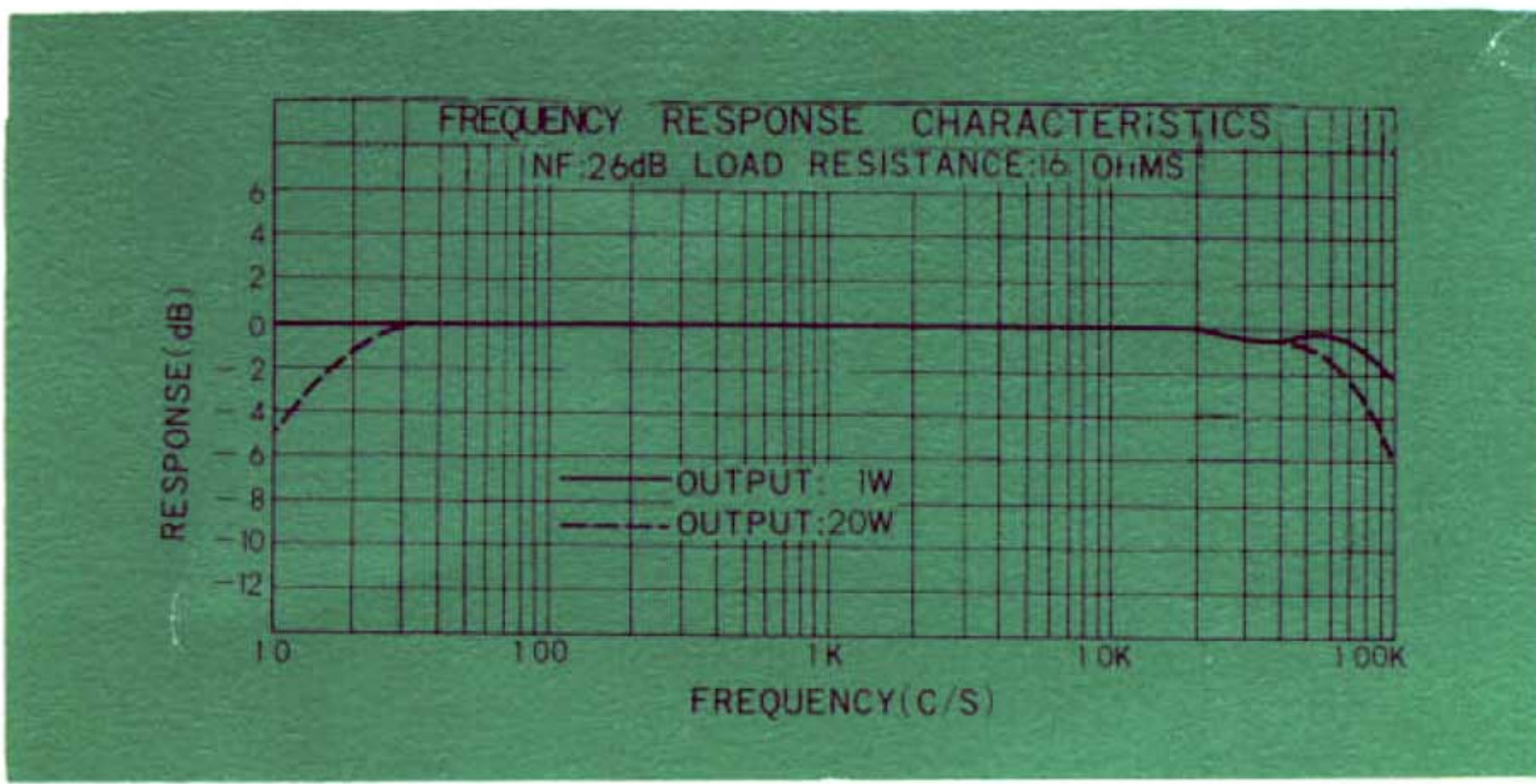

1. FREQUENCY
2. HARMONIC DISTORTION
3. INTERMODULATION DISTORTION
4. TONE CONTROL
5. LOW AND HIGH FILTERS
6. INPUT AND OUTPUT

CARTRIDGE SWITCH

SET THIS TO MAG OR X-TAL DEPENDING ON YOUR PLAYER CARTRIDGE
(MAGNETIC OR CRYSTAL)

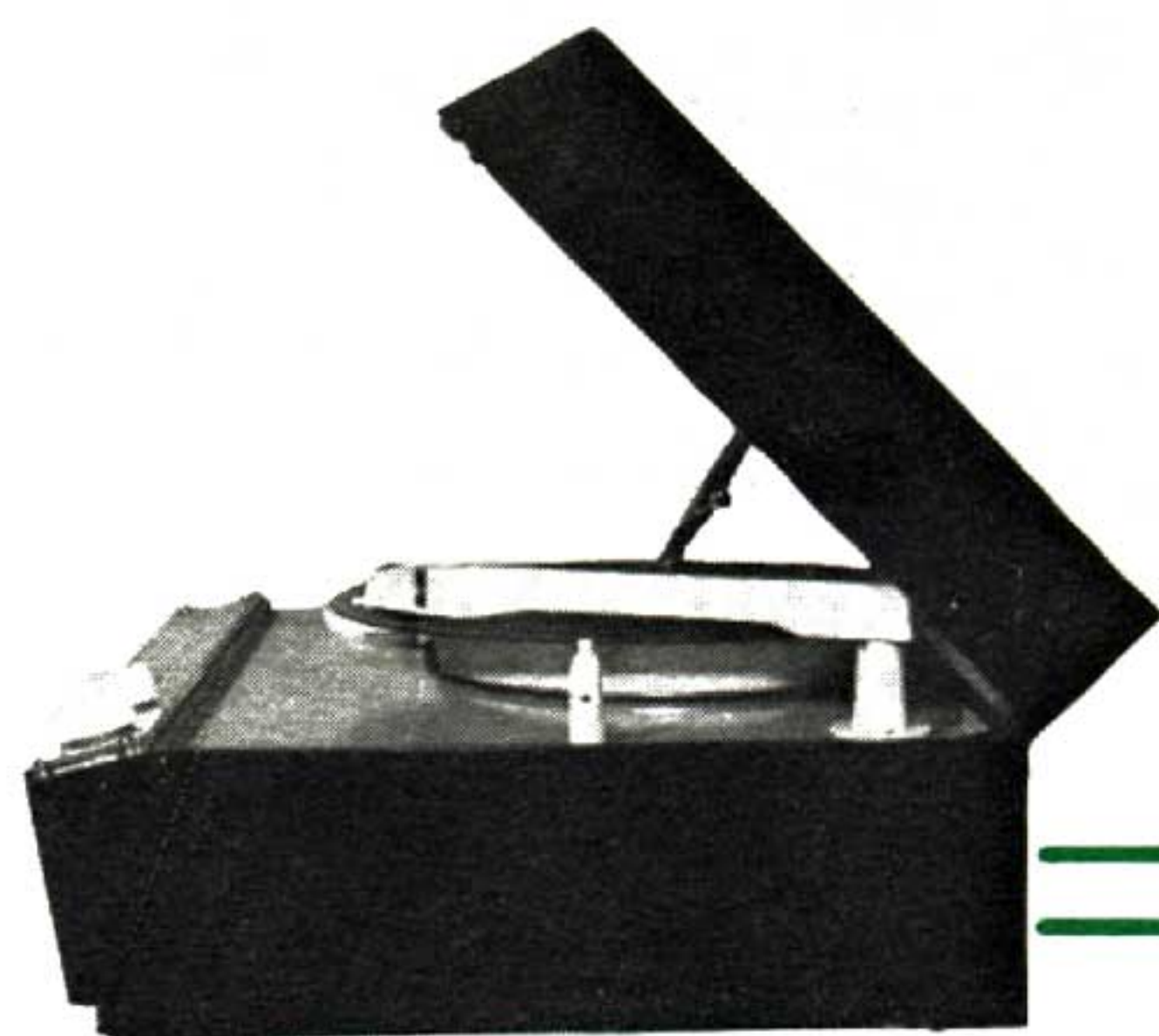

RECORD PLAYER

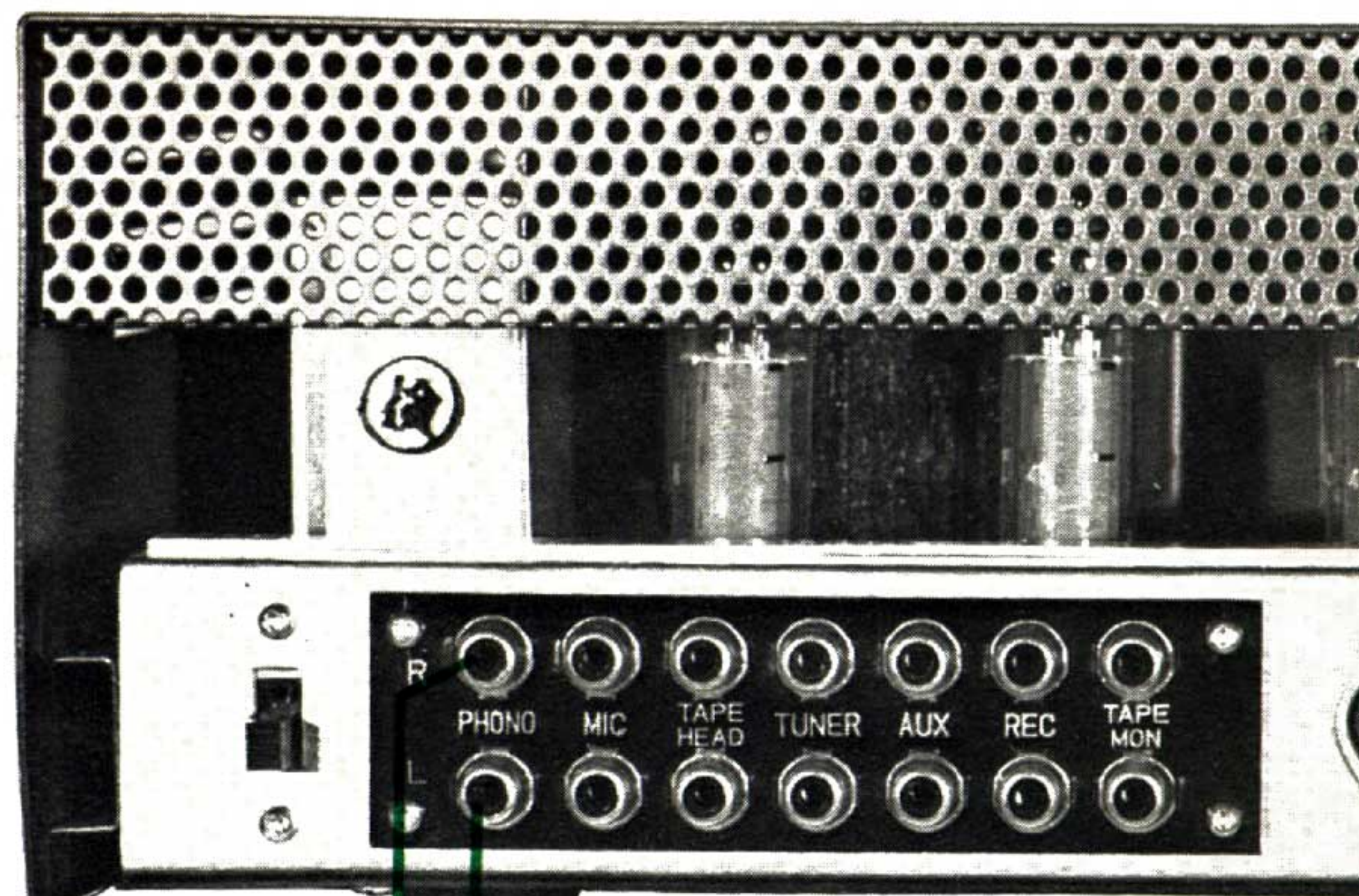

THIS IS USED TO SELECT THE MOST SUITABLE METER SENSITIVITY FROM THE THREE RANGES OF 5, 10 AND 25 WATTS. THE VARIABLE SENSITIVITY IS INTENDED TO MAKE IT EASIER TO WATCH NEEDLE MOVEMENT.

HIGH: UP TO 5 WATTS

MEDIUM: UP TO 10 WATTS

LOW: UP TO 25 WATTS (MAXIMUM OUTPUT)

CHOOSE THE APPROPRIATE RANGE ACCORDING TO VOLUME

HOW TO PLAY RECORDS

● Record Player Connection

1. Connect the output terminal to the "PHONO-R" and "PHONO-L" terminals (in the case of monaural reproduction, to either of these terminals) on the back of your amplifier with shield wires.
2. Set the cartridge switch on the back of your amplifier to "MAG" or "X-TAL" according to the type of your cartridge.
3. Connect the power-cord plug receptacle of the player to the power plug on the back of your amplifier.

● Operation

1. Set the "SELECTOR" switch at "PHONO".
2. Set the "MODE" switch at "STEREO" or "STEREO-REV" (at R or L in case of monaural operation).
3. Switch on the player, put on the record and adjust the number of revolutions as necessary before placing the pickup on the record.
4. Balance the sounds from both speakers by means of the "BALANCE" knob while watching the output level meters.
5. Adjust the amount of sound by means of the "VOLUME" knob. Other adjusting knobs and switches can be used to get the most satisfactory reproduction.

When you play a monaural record on a stereo record player, follow the same procedure as for stereo records. This will give you better results.

Cartridges are either magnetic or crystal. Both can be used with the AU-70, but, if possible, use the magnetic type for the highest fidelity. If you feel that right and left are reversed when playing a stereo record, turn the "MODE" switch to "STEREO-REV". To balance the sounds from both speakers, play a monaural record in the same way as a stereo record and adjust the "BALANCE" switch in such a way that you feel that the sound comes from a point midway between the right and left speakers. In this case, you can count on the output level meters for a rough determination of the balance. Also, make sure that the "BLEND" knob is kept at the point where it cannot be turned clockwise any further.

When you supply power to the player from the power-plug receptacle on the back of your amplifier, do not forget that the player is switched off when you switch off the amplifier.

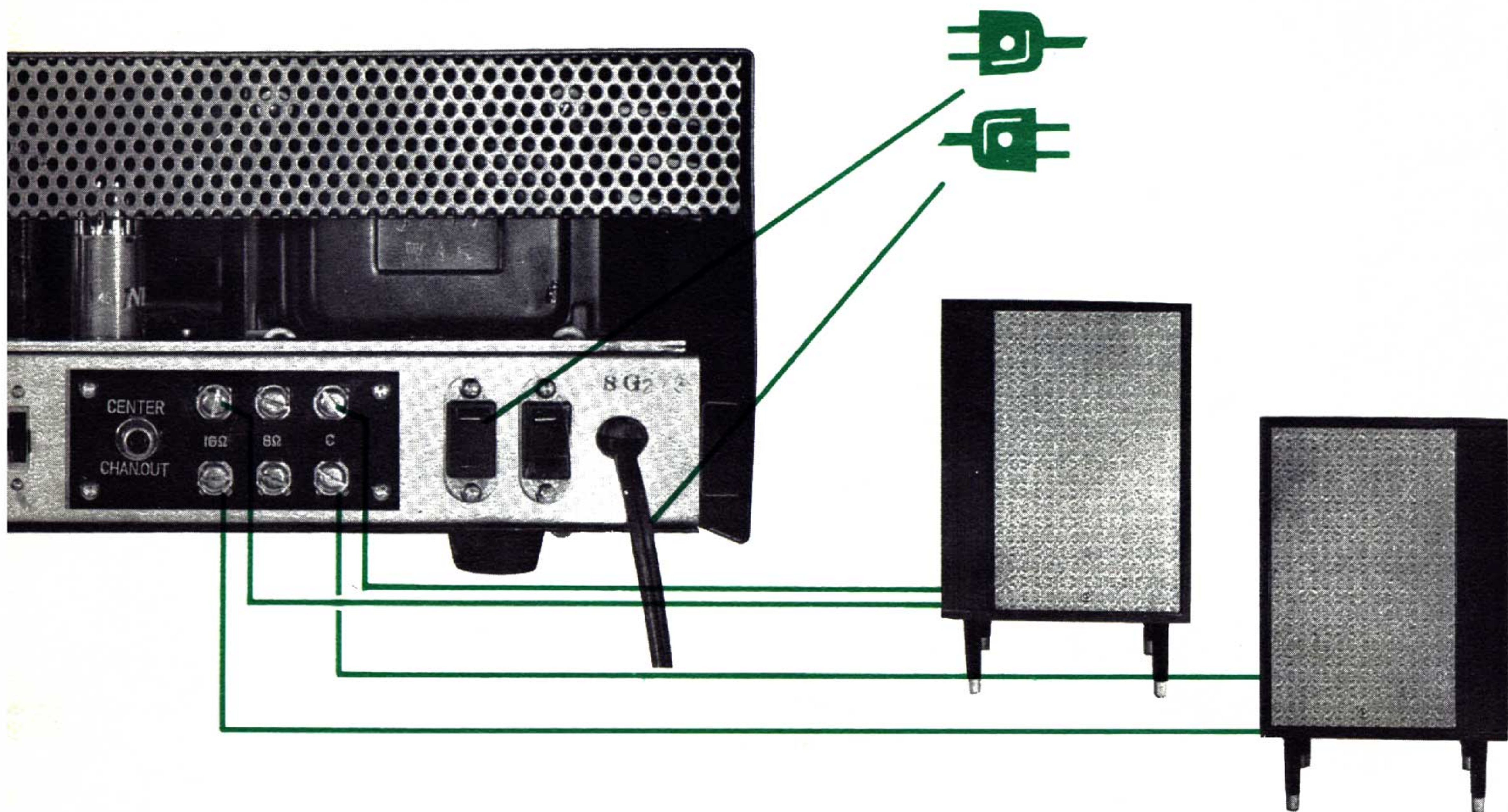

SPEAKERS

● Stereophonic Reproduction

Connect (+) of the right-hand speaker to the 8- or 16-ohm terminal of the upper R terminals on the back of the amplifier. Connect (-) of the right-hand speaker to (C) of the upper R terminals. Connect (+) of the left-hand speaker to the 8- or 16-ohm terminal of the lower L terminals on the back of the amplifier. Connect (-) of the left-hand speaker to (C) of the lower L terminals.

● Monaural Reproduction

When you use an 8-ohm speaker system for monaural reproduction, connect the upper and lower 16-ohm speaker terminals of your amplifier to the (+) terminal of the speaker.

Connect the upper and lower (C) speaker terminals of your amplifier to the (-) terminal of the speaker.

Three-dimensional Stereophonic Reproduction

● Your Sansui amplifier is equipped with a terminal for a center-channel amplifier so that it can be used for three-dimensional reproduction.

To do this, connect the input terminal of a monaural amplifier (Either a main or combination amplifier can be used. Among our own products, the Q-15 main amplifier is the most suitable.) to the pin jack of the center-channel

output terminal at the left of the speaker terminal board with a shieldwire. The center channel mixes the right and left sounds to produce the three-dimensional effect. Speakers suitable for the AU-70 are 20 to 30-cm coaxial speakers and, for the best musical reproduction, two- or three-way speaker systems which use different speakers for different frequency ranges.

In choosing the cabinet, take account of tonal quality in addition to design.

If you find that the sounds from both speakers do not mix well, but leave a sort of vacuum midway between the speakers, you can conclude that the amplifier and the speakers do not match in polarity (phase). In such a case, reverse the (+) and (-) connections of either speaker.

When you use two pairs of speakers for stereophonic reproduction, make sure that the speaker output terminal connections do not cause contact between R and L and that the terminals are connected properly. If the connections are faulty, your amplifier will not work normally and may also go out of order.

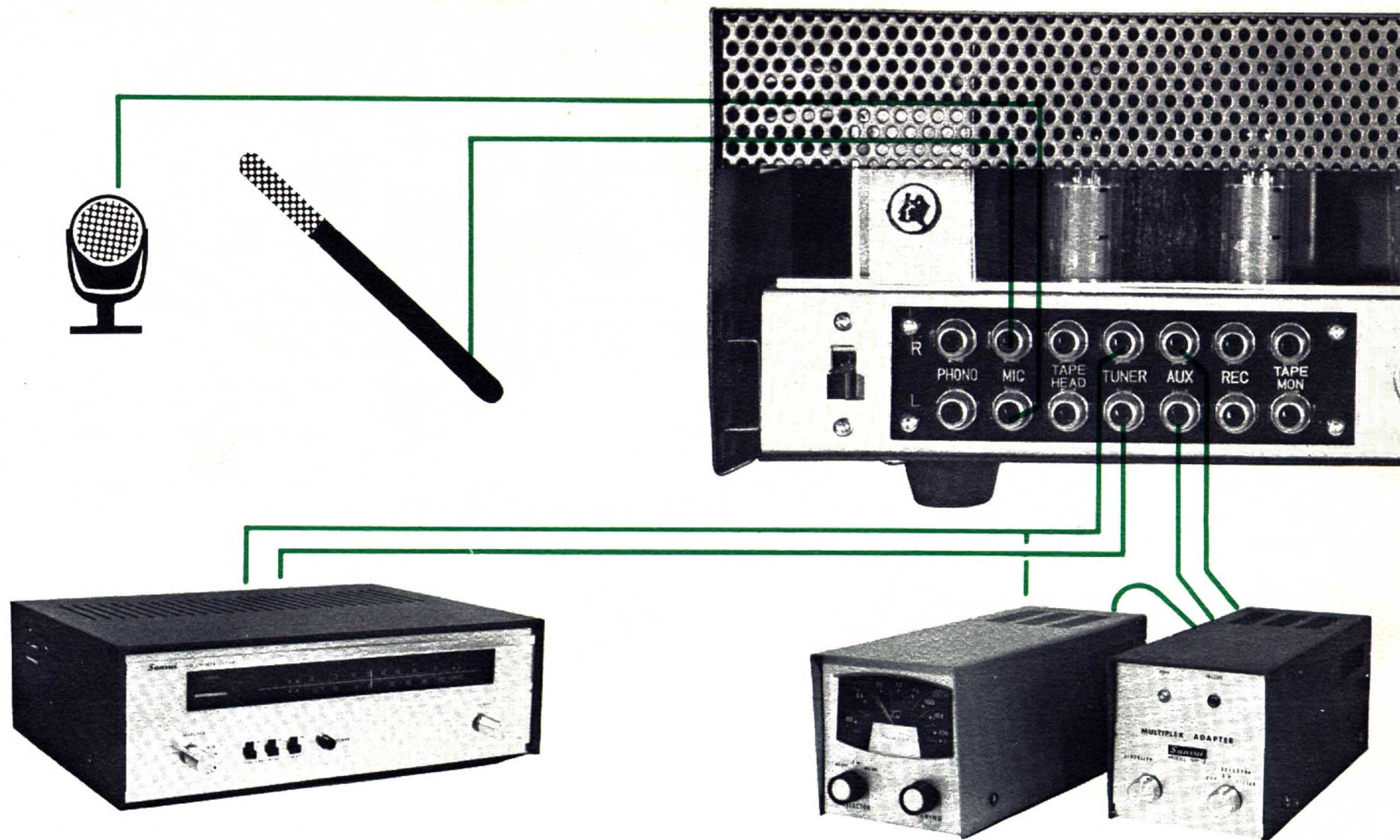

AM/FM/MPX TUNER (SANSUI TU-70)

FM TUNER (SANSUI FM-8) MPX ADAPTOR (SANSUI MP-2)

HOW TO RECEIVE BROADCASTS

You can listen to broadcasts easily by connecting your amplifier to a tuner and MPX adaptor.

● Connection

A. Stereo tuner

Connect tuner output to the R and L "TUNER" terminals on the back of your amplifier.

B. Monaural tuner

Connect tuner output to either R or L of the "TUNER" terminals on the back of your amplifier.

C. FM monaural tuner and FM-MPX adaptor.

Connect monaural tuner output to the input terminal of the FM-MPX adaptor and connect R and L of the adaptor output terminals to R and L, respectively, of the "AUX" terminals on the back of your amplifier.

● Operation

In the case of A and B above:

1. Set the "SELECTOR" switch at "TUNER".
2. Set the "MODE" switch at "STEREO" or "STEREO-REV" in the case of A and at R

or L (according to the channel selected) in the case of B.

3. Tune in with the tuner.
4. Use other adjusting knobs and switches to get the most satisfactory performance.

In the case of C

1. Set the "SELECTOR" switch at "AUX".
2. Set the "MODE" switch at "STEREO" or "STEREO-REV".
3. Tune in with the tuner.
4. Prepare the FM-MPX adaptor for stereophonic reception.
5. Use other adjusting knobs and switches to get the most satisfactory performance.

When you use a tuner or FM-MPX receiver, read the instructions for them carefully. There should be no mistakes in connections and operation.

When you use our TU-70, follow the instructions for A. When you use FM-8 and MP-2, follow the instructions for C.

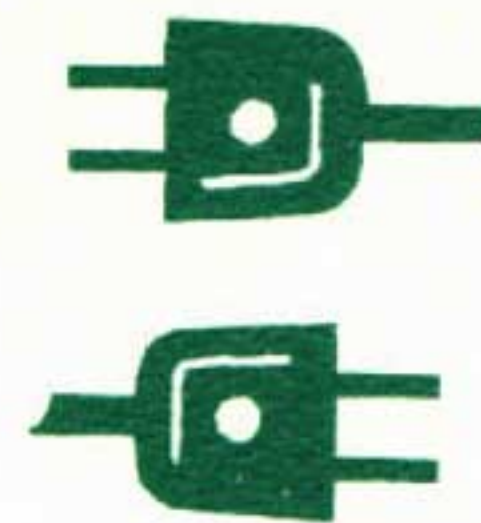
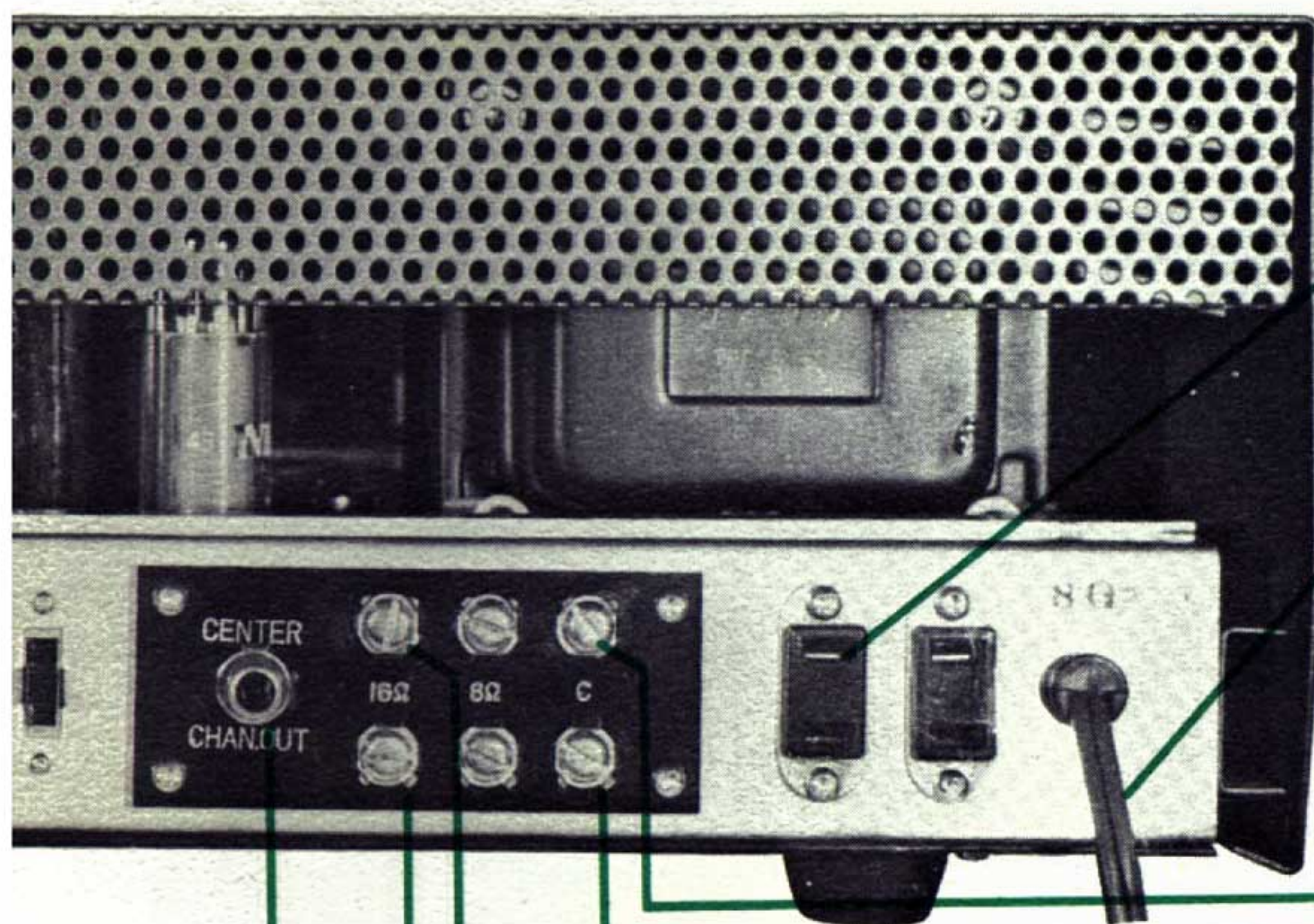

POWER SUPPLY
TO PLAYER AND
TUNER
(THESE TWO PLUG
RECEPTACLES CANNOT
BE USED FOR OVER
150 VA.)
TO A-C LINE
(INSERT IN A PLUG
RECEPTACLE IN YOUR HOME)

NAURAL AMPLIFIER
ANSUI POWER AMPLIFIER
.5)

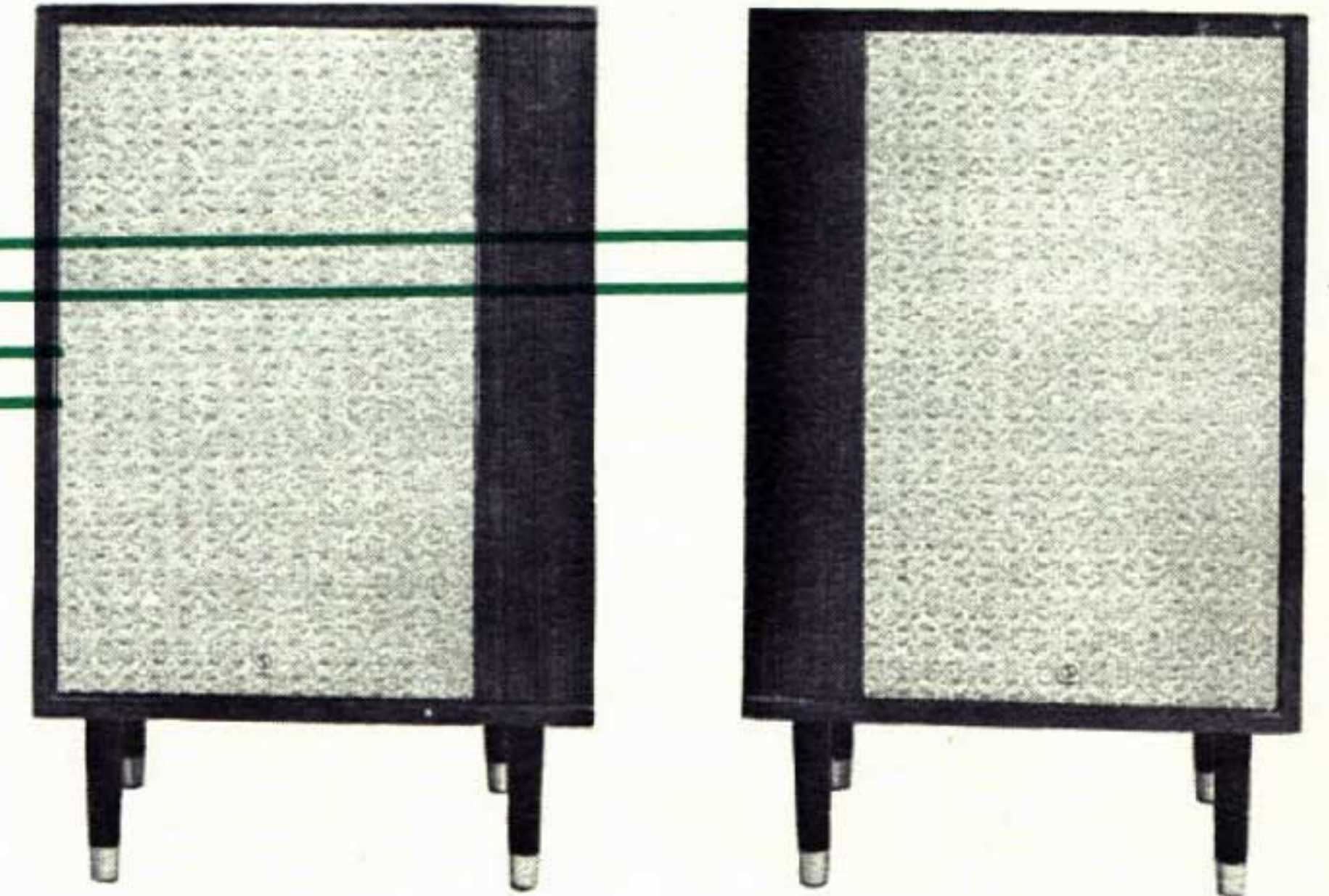

SPEAKERS, 16 OHMS EACH

HOW TO USE A MICROPHONE

You can use a microphone with your AU-70 amplifier. Any high-impedance (50-kilo-ohm) crystal, dynamic or velocity microphone is acceptable.

● Connection

Connect the microphone to R or L of the "MIC" terminals on the back of your amplifier. When you use two microphones, connect one to R and the other to L.

● Operation

1. Set the "SELECTOR" switch at "MIC".
2. Set the "MODE" switch at "STEREO" (when you use only one microphone for stereophonic effect)
 - at R (when you use only one microphone for monaural reproduction),
 - or at L+R (when you mix two different program sources from two microphones.)
3. During stereophonic operation, you can use the "BLEND" knob for mixing purposes.

4. Other adjusting knobs and switches can be used for the most satisfactory reproduction. Remember that your AU-70 amplifier accepts only high-impedance microphones. You cannot get the best performance if you use too long a microphone cord, which causes various problems and reduces treble. Your amplifier has separate tone controls for right and left speakers. You will find this feature very useful when you use one microphone for music and another for voice. Furthermore, it gives added versatility to your amplifier, particularly when you record on tape what is picked up by microphones.



POWER INDICATOR

This lights up when power is being used. It remains on while the amplifier is in operation.

HEADPHONE JACK

When you want to avoid disturbing others or when you use the amplifier as a monitor, connect the headphones to this jack. You can still enjoy stereophonic reproduction through these headphones. For this purpose, you can use any type of headphones or earphones if its plug fits into the jack. But use dynamic headphones designed for stereophonic reproduction, if possible.

SPEAKER (SPEAKER OFF)

When you use headphones with the headphone jack, set this switch to "OFF" to cut off sound to the speakers. This feature enables you to enjoy stereophonic reproduction without disturbing others.

PRESENCE

If the Tone Control alone is used for bass compensation, slightly higher frequencies are compensated at the same time. To avoid this, turn this switch "ON". This sets the turnover at 150 cps, changing speaker damping and frequency response characteristics to compensate bass. As a result, all sounds become impressive and you can enjoy clear, magnificent bass.

POWER

This switch is used for connecting and disconnecting the power supply. Push the button for power. Push it again to shut it off. The switch also activates and deactivates the power-supply plug receptacle on the back of the amplifier.

BALANCE

This knob is used to adjust the balance of volume between the right and left speakers for the best stereophonic effect. Make the adjustment while watching the output level meters and listening to the sounds of both speakers. When the amplifier is adjusted properly, you feel as if the sound comes from a point midway between the two speakers.

BLEND

This knob permits continuous shift from stereophonic to monaural reproduction. Turn it counterclockwise to bring reproduction closer to monaural (R—L). For complete monaural reproduction, turn it as far counterclockwise as possible.

The sounds of the right and left speakers become separated when you turn the knob clockwise (R and L perform their respective functions). The best stereophonic effect is obtained when you turn it as far as possible.

BASS and TREBLE for R and L

These control the tone of the right and left speakers. Use in the same way for both speakers.

VOLUME

This knob is used to control the volume of the tuner, records and tapes. Turn it clockwise for louder reproduction. To reduce the volume, turn counterclockwise.

LOUDNESS

When sound volume is at a low level, you feel as if bass and treble are missing. In such a case, turn this switch "ON" to compensate bass and treble. This will make you feel as if you were present at an actual concert.



TAPE MONITOR

When you make recordings with a three-head tape recorder, turn this switch "ON" to use the amplifier as a monitor. Then the sounds recorded on the tape will be reproduced while you are recording. Keep this switch "ON" when you play the tape on the tape recorder.

Be sure to keep the switch "OFF" otherwise.

TONE DEFEAT

Turn this switch "ON" to open the tone control circuit. Then the frequency response curve of the amplifier will become perfectly flat.

MODE (Stereophonic/monaural switch)

This switch is used to shift from stereophonic to monaural reproduction or vice versa.

STEREO:

Set the switch at this position for stereophonic reproduction. Signals fed into A come out of A's speaker and those fed into B come out of B's speaker.

STEREO-REV:

This position, too, is for stereophonic reproduction. But signals fed into A come out of B's speaker and those fed into B come out of A's speaker. Choose this position when the right and left are reversed in reproduction.

L+R:

Signals fed into L and R are blended into one (L+R) in the amplifier before they come out separately from L and R. Signals fed into A and B become A+B in the amplifier and come out of the speakers of A and B in the form of the combined sound A+B

R (Monaural R):

Signals fed into A come out of A's and B's speakers. Use this position for reproducing monaural broadcasts and tapes.

L (Monaural L):

Signals fed into B come out of A's and B's speakers. This position is rarely used.

OUTPUT LEVEL METERS

The right and left meters indicate the output levels of the right and left speakers, respectively.

Since output is shown separately for each channel, the meters make for easy balance adjustment. Besides, you can watch changes in the output of each channel during operation. Each meter can be set to any of the three ranges of 5, 10 and 25 watts by means of the output-level meter switch on the back of the amplifier. Choose the appropriate range according to the output you want. When the mode switch is set at R (or L), the meter for L (or R) does not work.

SELECTOR (INPUT-SELECTOR)

TUNER: For receiving broadcasts through the tuner.

PHONO: For playing records.

MIC: For using a microphone

TAPE HEAD: For playing tapes on the tape deck (directly from the tape head).

AUX: For reproducing voice input or using the MPX adaptor.

LOW FILTER (for eliminating low-frequency noise)

Turn this switch "ON" to reduce phonomotor and other unpleasant low-frequency noises.

HIGH FILTER (for eliminating high-frequency noise)

Turn this switch "ON" to reduce relatively high-frequency noise, such as the scratch from records made of poor material or noise due to fluorescent lamps in the case of the tuner.

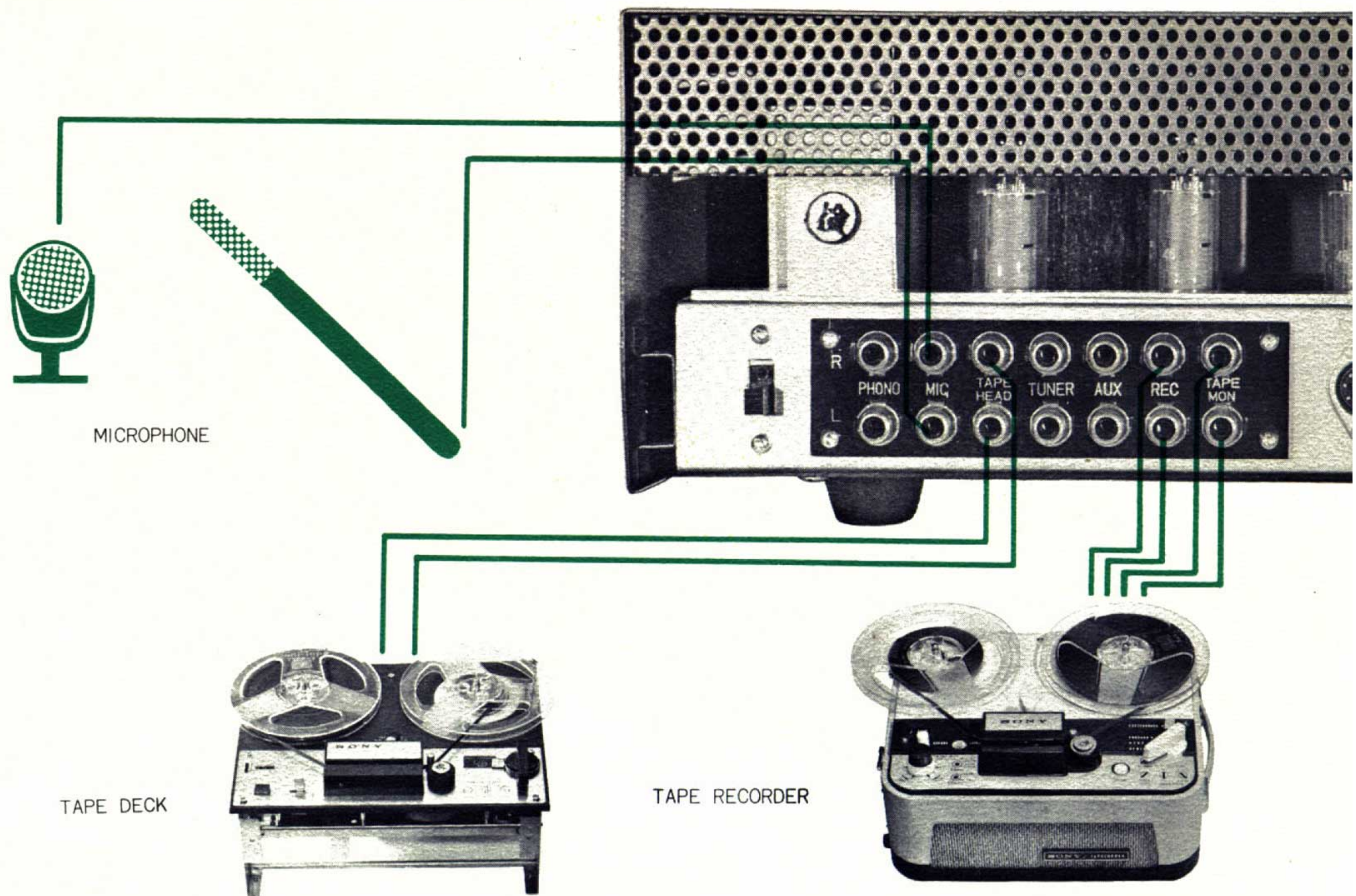

HOW TO RECORD AND PLAY TAPES

Your AU-70 amplifier can be used with a tape recorder for recording and playback and can also play tapes on the tape deck. If you use a three-head tape recorder which has separate record and playback heads, you can make recordings while listening to a reproduction of the recordings. In other words, your amplifier can be used as a monitor which lets you know the quality of your recordings while they are being made.

● Connection

1. Single-connection tape recorder (DIN standard specification): Connect the single-connection connector to the "TAPE-REC" plug on the back of your amplifier.
2. Pin-jack tape recorder
 - a) Recording
Connect the tape recorder input terminal to R and L (R or L in the case of monaural operation) of the "REC" terminals on the back of your amplifier with shieldwires.
 - b) Playback
Connect the tape recorder output terminal ("LINE") to R and L (R or L in the case of monaural operation) of the

"TAPE MON" terminals on the back of your amplifier.

3. Playing tapes on the tape deck
Connect the tape deck output terminal to R and L (R or L in the case of monaural operation) of the "TAPE" terminals on the back of your amplifier.
4. Monitoring with a three-head tape recorder
 - a) Single-connection tape recorder
Connect the single-connection plug to the "TAPE-REC" receptacle on the back of your amplifier.
 - b) Pin-jack tape recorder
Connect the tape recorder input terminal to R and L (R or L in the case of monaural operation) of the "REC" terminals on the back of your amplifier. Also, connect the tape recorder output terminal "LINE" to R and L (R or L in the case of monaural operation) of the "TAPE MON" terminals on the back of your amplifier.

● Operation

Recording

1. Set the "SELECTOR" switch at the proper

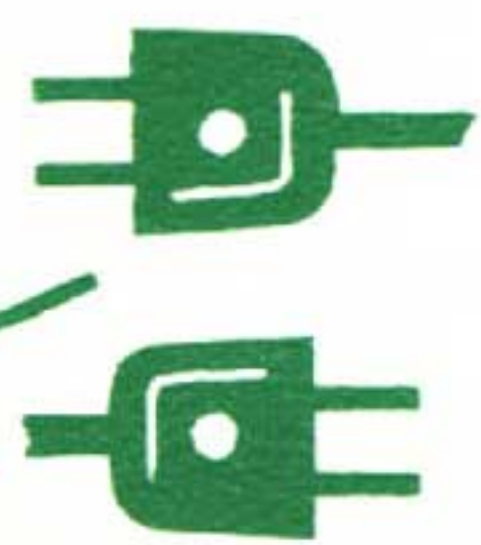
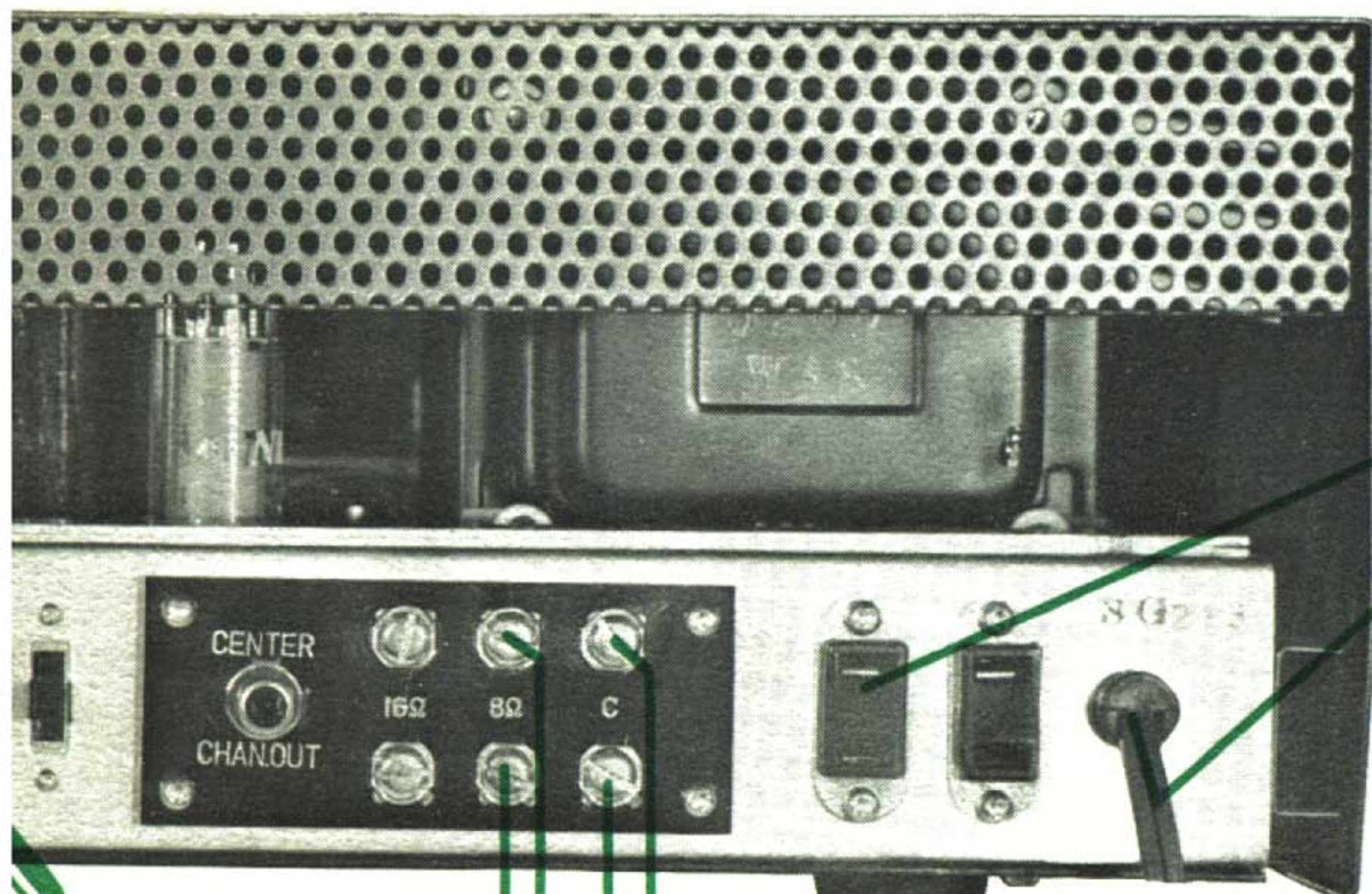

POWER SUPPLY
TO PLAYER AND
TUNER
(THESE TWO PLUG
RECEPTACLES CANNOT
BE USED FOR OVER
150 VA.)
TO A-C LINE
(INSERT IN A PLUG
RECEPTACLE IN YOUR HOME)

DIN plug connection

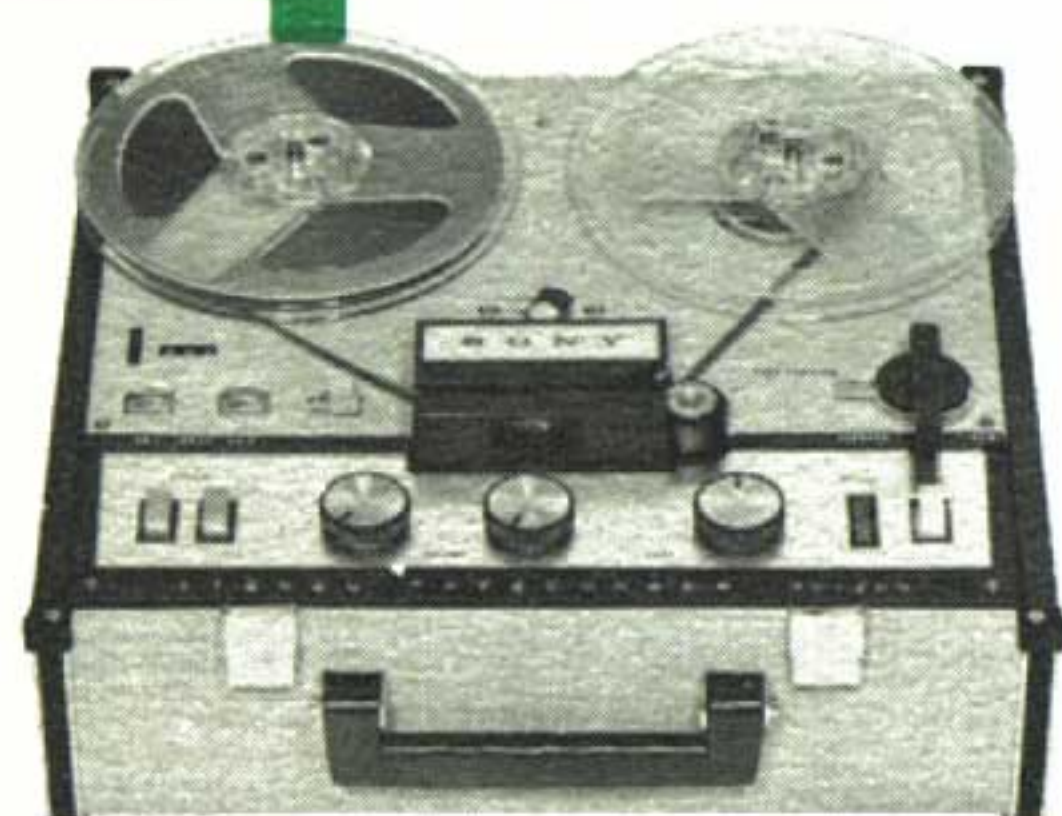

SINGLE-CONNECTION TAPE RECORDER

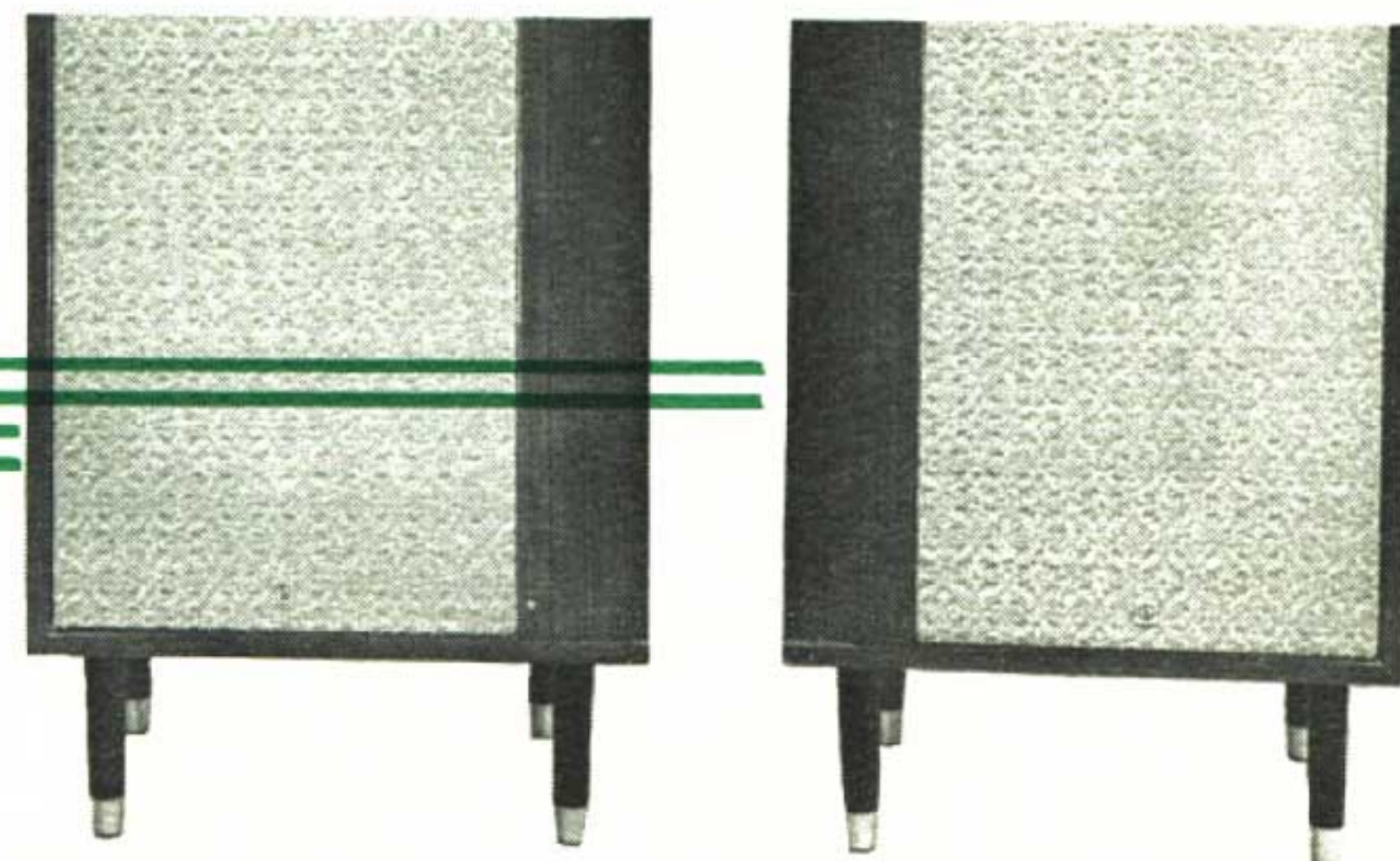

SPEAKERS, 16 OHMS EACH

- position according to the program source (broadcast or record) you are going to record.
2. Set the "MODE" switch at "STEREO" (for stereophonic recording), at R or L (for monaural recording), or at L+R (for monaural recording of a stereophonic source).
3. Prepare the tape recorder for recording.
4. Operate the recorder and amplifier adjusting knobs and switches properly.

Amplifier adjusting knobs do not affect the level and tonal quality of recordings, but only control those of the sound from the speakers. When you record a broadcast or record, you can obtain better results by connecting the tape recorder directly to your amplifier instead of picking up the sound from the speakers with microphones.

Playback

1. a) Tape deck
Set the "SELECTOR" switch at "TAPE".
- b) Tape recorder
Set the "TAPE MON" switch at "ON".
2. Set the tape recorder in the play position.
3. Other adjusting knobs and switches can be used for the most satisfactory reproduction.

Caution

When you use the Tape Recorder, Keeping on "Tape monitor switch at "ON", in such a case, it can not use for mode switch".

If you want to use a mode switch, connect the recorder out put to the "AUX" pin jack on the back of your amplifier and "Tape monitor switch at off.

Tape Monitoring

To use your amplifier as a monitor for a three-head tape recorder, follow the same procedure as the one for playing tapes on a recorder. When you use a recorder, read the instruction manual carefully to avoid errors in connection and operation.

Unless you use your amplifier as a tape monitor or for playing a tape with a tape recorder, be sure to switch off the "TAPE MON" switch.

Connecting a tape recorder can be done using either a single-connection connector or by a pin-jack. The single-connection plug conforms with German DIN standard specifications. It makes it easier to connect the tape recorder to your amplifier because it has a five-pin plug for both record and playback. When you use your amplifier as a tape monitor, turn on the "TONE DEFEAT" switch if you want to hear the sound you are recording.

TROUBLE-SHOOTING HINTS

● Speaker Polarity

If the phase (polarity, viz. + and -) of the right and left speakers is not correct, sounds at the center of the frequency range become weak. You will particularly sense an attenuation of bass. To make sure that speaker polarity is all right, play a monaural record on a stereo record player. If the polarity is reversed you will have the result mentioned above. In such a case, reverse the polarity of either speaker. (Connect the - leadwire to +) When both speakers are thus made to agree in polarity, you will feel as if the sound comes out of a single speaker placed midway between the right and left speakers.

● Fuse

The amplifier does not work when the fuse is blown. In such a case, disconnect the power cord and replace the fuse on the back of the amplifier. Use a 3-ampere fuse encased in a glass tube. Never risk the danger of using fine wire or a fuse of a larger capacity as a substitute. If the fuse has burnt out because the amplifier is out of order, locate the trouble and repair it before replacing the fuse. The fuse blows if you use an AC plug receptacle larger than the specified capacity (150 VA for two).

● Heat Generated by Amplifier

The top of the amplifier case becomes considerably hot after many hours of continuous operation. But this should not worry you because air vents are provided on the top and back of the case. If you place something on the amplifier or put it in a closed box, or keep its front panel facing up, it might go out of order.

● Connections

When you connect your amplifier to a tape recorder or tuner, be sure to use an adequately thick shieldwire. If you use an untwisted vinyl cord like those used for lights, you will suffer from hum. Furthermore, do not use a wire longer than 2 meters (about 6.5 ft.) because the longer the connecting wire is, the greater the attenuation of treble becomes. For connection to a tuner or FM adaptor, use a wire 1 to 1.5 meters (about 3.3 to 4.8 ft.) long. When you use the amplifier for monaural reproduction, it is easier for operation to use the upper R terminal for connection. Be sure to set the "MODE" switch to the connected channel.

● Hum and Howling

When you play a record or tape, you may sometimes hear unpleasant humming or howling. This does not mean that your amplifier is defective. In most cases, humming or howling is a result of these causes:

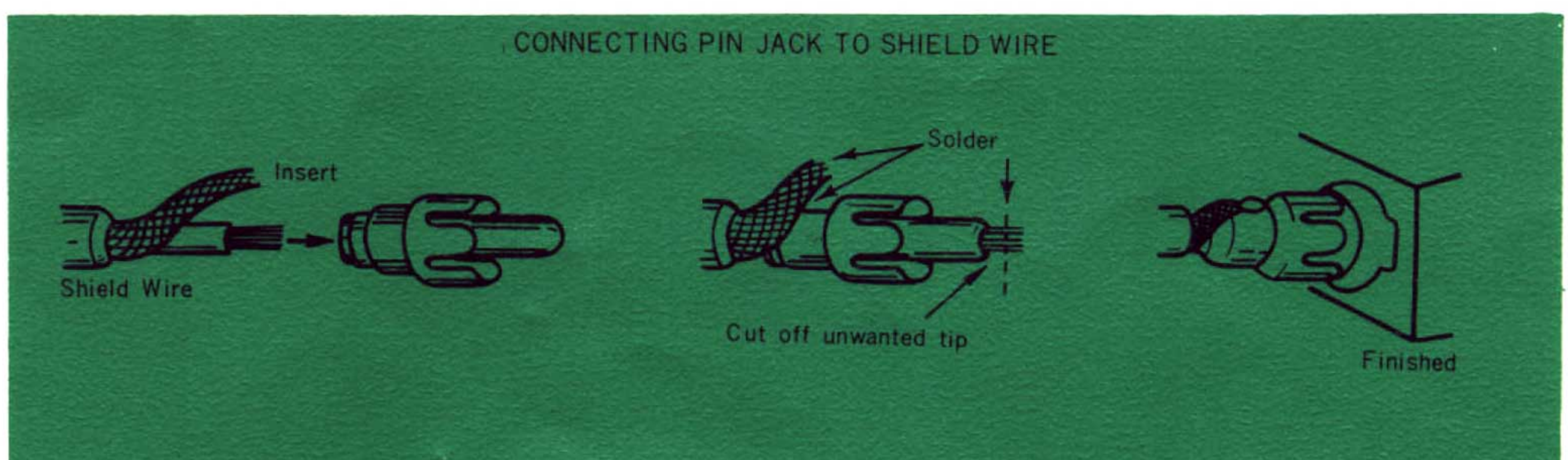

If you place a record player on or near the speaker box, the vibrations of the speaker cabinet caused by the sound waves from the speaker are transmitted to the player and cause howling. To prevent this, keep the record player away from the speaker cabinet or put a thick cushion between the player and the cabinet.

A low, buzzing sound will also be produced if you do not use shieldwire for connection. If this is not the cause, examine the connections closely. Make sure that the earth and live ends are not reversed so that the motor and arm are inadequately grounded.

Connect Leadwires Properly

Connect leadwires properly to the speaker and other input and output terminals. If connections are loose or touch other parts, your amplifier will not work properly. Moreover, it may produce noise. If you use your amplifier in such a way for a long time, it may eventually break down. Finally, read the instructions for your tuner or tape recorder carefully before you connect it to your amplifier.

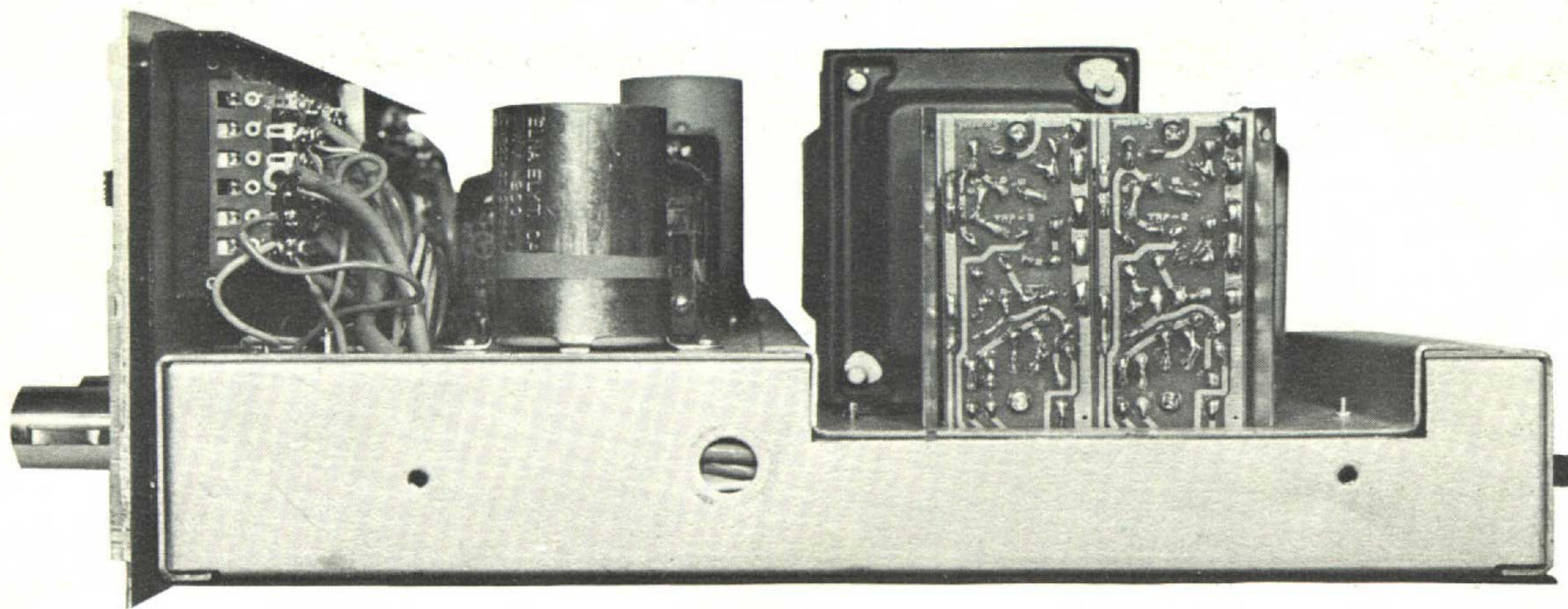

This amplifier has passed our rigorous inspections and is guaranteed against accident during transportation and against failure during use.

Return the enclosed user card, and you will receive a letter of guarantee. If your amplifier should go out of order within 12 months after the date of purchase, you can have it repaired free. (If you do not return the card, you will be asked to pay the net cost of repair, even during the 12-month guarantee period.)

Send back the card within one week after the date of purchase. After the guarantee period of one year, your amplifier will be repaired if necessary, at net cost.

Address your complaints and inquiries to our head office or the service section of our sales office in your neighborhood.

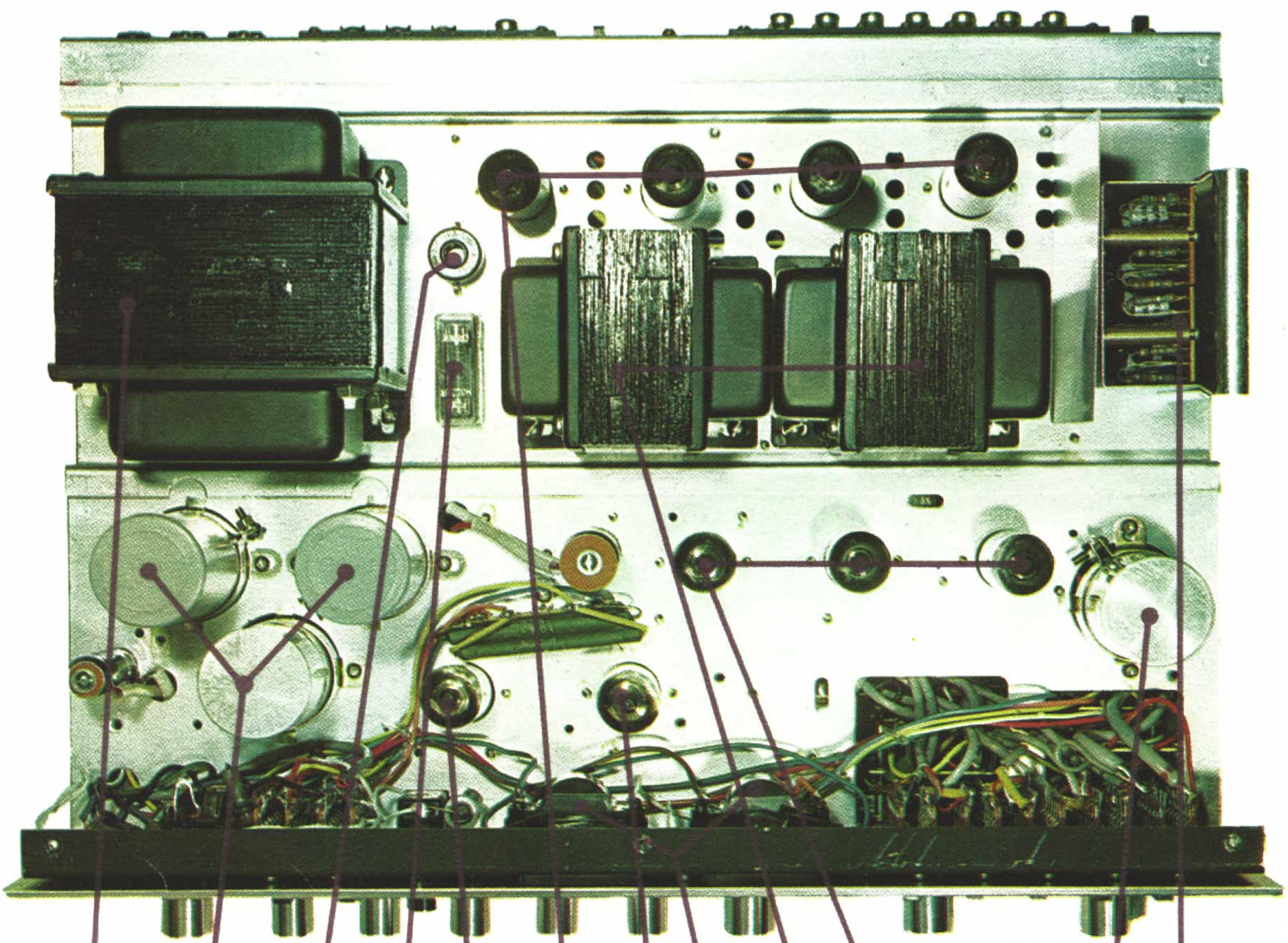

PT T1

Electrolytic Capacitor

Power Supply Switch Plug

Fuse Holder

V2

V9 V8 V7 V6

V1

Level Meter

T2 OPT. T3 OPT

V2 V4 V5

Electrolytic Capacitor

Transistor Pre amp.

WIRING DIAGRAM

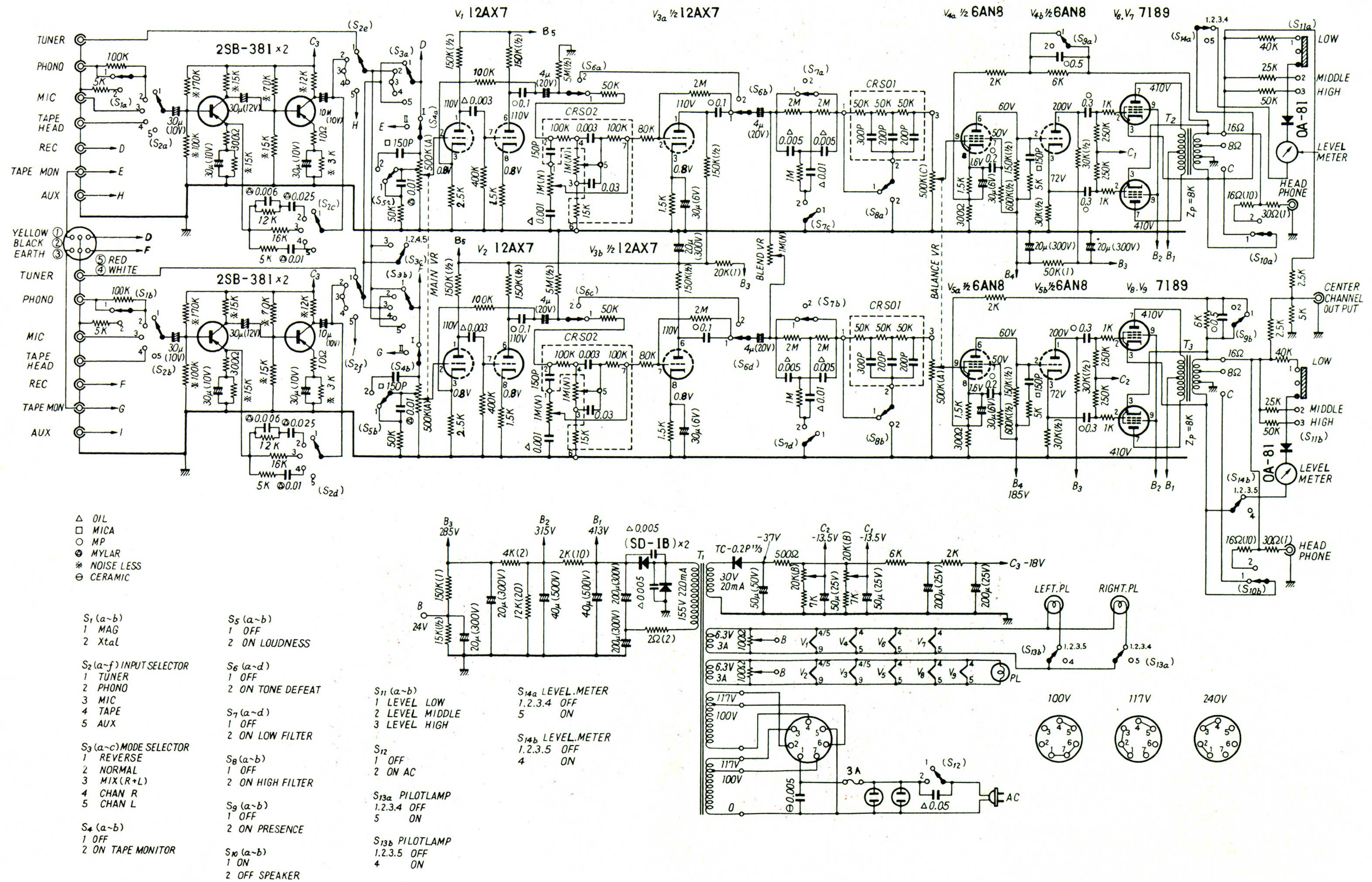

WIRING DIAGRAM

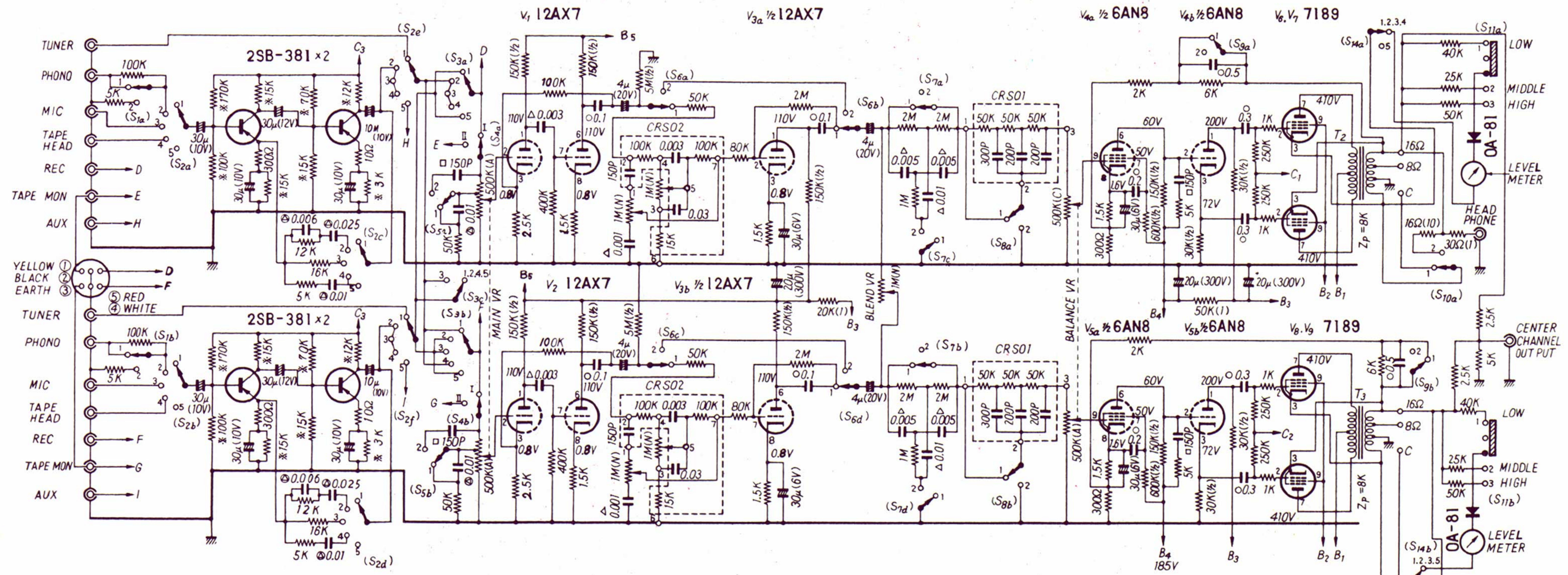

- △ OIL
- MICA
- MP
- MYLAR
- * NOISE LESS
- ⊖ CERAMIC

- S₁ (a-b)**
1 MAG
2 Xtal
- S₂ (a-f) INPUT SELECTOR**
1 TUNER
2 PHONO
3 MIC
4 TAPE
5 AUX
- S₃ (a-c) MODE SELECTOR**
1 REVERSE
2 NORMAL
3 MIX (R+L)
4 CHAN R
5 CHAN L
- S₄ (a-b)**
1 OFF
2 ON TAPE MONITOR

- S₅ (a-b)**
1 OFF
2 ON LOUDNESS
- S₆ (a-d)**
1 OFF
2 ON TONE DEFEAT
- S₇ (a-d)**
1 OFF
2 ON LOW FILTER
- S₈ (a-b)**
1 OFF
2 ON HIGH FILTER
- S₉ (a-b)**
1 OFF
2 ON PRESENCE
- S₁₀ (a-b)**
1 ON
2 OFF SPEAKER

- S₁₁ (a-b)**
1 LEVEL LOW
2 LEVEL MIDDLE
3 LEVEL HIGH
- S₁₂**
1 OFF
2 ON AC
- S_{13a} PILOT LAMP**
1.2.3.4 OFF
5 ON
- S_{13b} PILOT LAMP**
1.2.3.5 OFF
4 ON

- S_{14a} LEVEL METER**
1.2.3.4 OFF
5 ON
- S_{14b} LEVEL METER**
1.2.3.5 OFF
4 ON

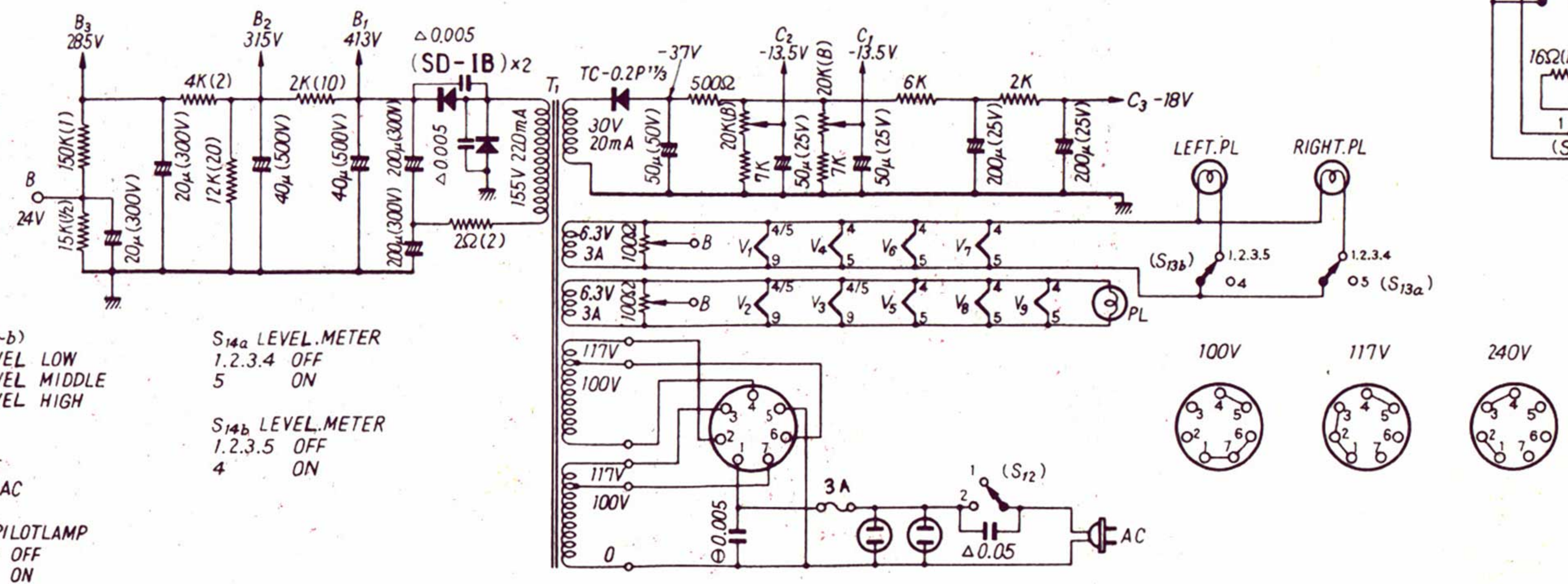

Some of the specifications might be changed without notice.

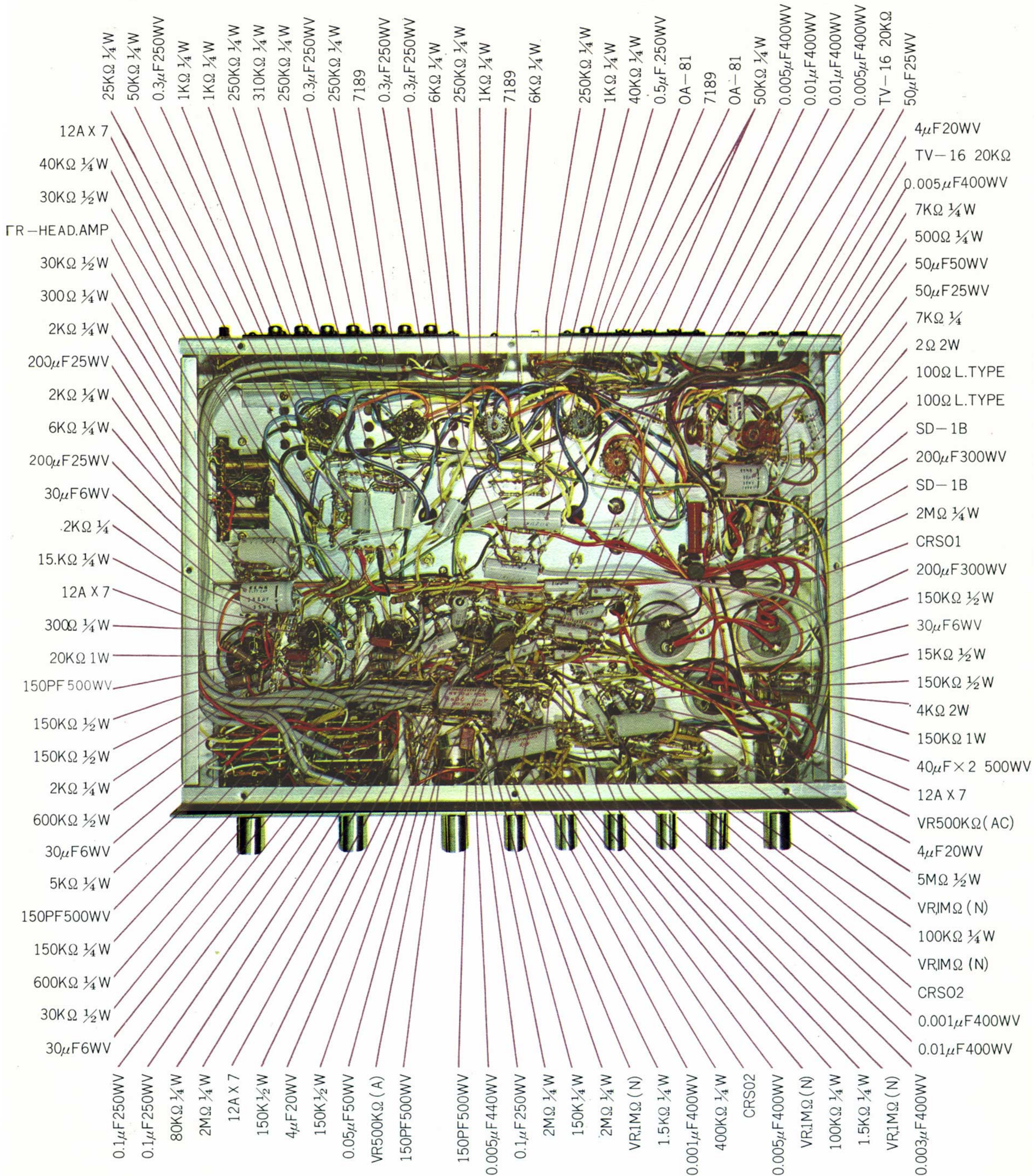

AU-70 PARTS LIST

Name	Specifications	quantity	Name	Specifications	quantity
Vacuum tube	7189A	4	Resistor	¼ watt, 1 kilo-ohm	4
" "	6AN8	(in two pairs) 2	" "	" " 1.5 kilo-ohms	8
" "	12AX7	3	" "	" " 2 kilo-ohms	3
Transistor	2SB-381	4	" "	" " 2.5 kilo-ohms	2
Germanium diode	OA-91	2	" "	" " 7 kilo-ohms	2
Selenium rectifier	TCO.2P-11/3	1	" "	" " 5 kilo-ohms	7
Silicon diode	SD-1B	2	" "	" " 3 kilo-ohms noiseless	2
Output transformer		2	" "	" " 12 kilo-ohms noiseless	2
Power transformer		1	" "	" " 12 kilo-ohms	2
Rotary switch	3-6-5	1	" "	" " 16 kilo-ohms	2
" "	3-7-5	1	" "	" " 25 kilo-ohms	2
Variable resistor	1 megohm, (N), 24-type	5	" "	" " 15 kilo-ohms noiseless	8
" "	500 kilo-ohms, (A), 120 kilo-ohms, with tap, 24-type, 2-gang	1	" "	" " 50 kilo-ohms	6
" "	500 kilo-ohms, (A.C)	1	" "	" " 60 kilo-ohms	2
" "	TV-16, 20 kilo-ohms, (B)	2	" "	" " 100 kilo-ohms	2
Hum balancer	100 ohms, L-type	2	" "	" " 100 kilo-ohms noiseless	2
Composite part	CRSO1	2	" "	" " 70 kilo-ohms noiseless	2
" "	CRSO2	2	" "	" " 170 kilo-ohms noiseless	2
Fuse-holder	1-p, covered	1	" "	" " 250 kilo-ohms	4
Fuse	3 amperes	1	" "	" " 1 megohm	2
Earphone jack	SG-4601	1	" "	" " 2 megohms	6
Power source transfer switch	S-291	1	" "	" " 400 kilo-ohms	2
AC plug receptacle	Square, small	2	" "	" " 40 kilo-ohms	2
5-p connector receptacle	DIN standard	1	" "	" " 80 kilo-ohms	2
Slide switch	SL-42E	7	" "	" " 6 kilo-ohms	3
" "	13SSL-622	1	" "	½ watt, 15 kilo-ohms	1
" "	SL-83	1	" "	" " 30 kilo-ohms	4
Push switch	Specal, 63.9	1	" "	" " 150 kilo-ohms	8
Pilot lamp	8 volts	3	" "	" " 600 kilo-ohms	2
Pilot lamp socket	S-469	3	" "	" " 5 megohms	2
Base for printed circuit	TRP-2	2	" "	1 watt, 30 ohms	2
Cord clip	Molded	1	" "	" " 20 kilo-ohms	1
Level meter	300-type, A-304	2	" "	" " 50 kilo-ohms	1
Tube socket	9-pin, molded	9	" "	" " 150 kilo-ohms	1
" "	7-pin, molded	1	" "	2 watts, 4 kilo-ohms	1
Lug, self-supporting, small	1L, 4-p	12	" "	" " 2 ohms	1
Lug, self-supporting	1L, 2-p	3	" "	10 watts, 16 ohms	2
" "	1L, 3-p	1	Oil capacitor	0.001 microfarad	2
" "	1L, 4-p	12	" "	0.003 microfarad	2
" "	1L, 6-p	1	" "	0.005 microfarad	6
Electrolytic capacitor	WV 300 volts, 200 microfarads	2	" "	0.005 microfarad	1
" "	WV 500 volts, 40 microfarads × 2	1	" "	0.01 microfarad	2
" "	WV 300 volts, 20 microfarads × 4	1	MP capacitor	0.1 microfarad	4
" "	WV 50 volts, 50 microfarads	1	" "	0.2 microfarad	2
" "	WV 25 volts, 50 microfarads	2	" "	0.3 microfarad	4
" "	WV 25 volts, 200 microfarads	2	" "	0.5 microfarad	2
" "	WV 6 volts, 30 microfarads	4	Myler capacitor	0.01 microfarad	4
" "	WV 12 volts, 30 microfarads	2	" "	0.006 microfarad	2
" "	WV 10 volts, 30 microfarads	6	" "	0.025 microfarad	2
" "	WV 12 volts, 10 microfarads	2	" "	0.05 microfarad	2
" "	WV 20 volts, 4 microfarads	4	Mica capacitor	150 micromicrofarads	4
Ceramic resistor	12 kilo-ohms, 20 watts	1	Ceramic capacitor	0.005 microfarad	1
" "	2 kilo-ohms, 10 watts	1	Catalogue		1
Resistor	¼ watt, 10 ohms	2	AC cord	8 feet	1
" "	" " 300 ohms	4	Input terminal plate		1
" "	" " 500 ohms	1	Output terminal plate		1
			Antenna terminal plate		1

Head Office; 460, Izumi-cho, Suginami-ku, Tokyo, Japan. Tel. Tokyo 328-0111
 Osaka Branch; 4-8, Miyakojima, Minamidori, Miyakojima-ku, Osaka. Tel. Osaka 928-4391
 Nagoya Branch; 2-11, Hanaomote-cho, Atsuta-ku, Nagoya. Tel. Nagoya 88-8463
 Fukuoka Branch; 2-16, Okamoto, Kasuga-cho, Tsukushi-gun, Fukuoka. Tel. Fukuoka 58-1253
 Show Room; 42, Sanko-cho, Shinjuku-ku, Tokyo. Tel. Tokyo 368-4586



MODEL **AU-70**



SERVICE NOTE

Symptom	Probable Cause	What to Do
No power when power switch is pushed on	<ol style="list-style-type: none"> Defective power switch. Defective line cord. Loose contact between plug and socket or defective plug. Blown fuse. 	<p>Replace.</p> <p>Replace.</p> <p>Recondition or replace.</p> <p>Replace.</p> <p>If again blown after replacing, check power transformer (T₁) & path condenser (C₉₁) in power circuit for short-circuit.</p>
Power indicator is lit when power switch is pushed on, but; A. the unit does not work at all.	<ol style="list-style-type: none"> Defective tube. Abnormal voltage in tubes and other parts. 	<p>Check V₁~V₉ and silicon diodes.</p> <p>Check voltage in tube and other parts and replace, if necessary. If voltage is OK, check AUX input circuit and hereafter.</p>
B. PHONO and TAPE does not function.	<ol style="list-style-type: none"> Defective head amplifier (transistor section). Defective selector switch. Loose contact or short-circuit between input terminal and pin-jack. Defective record player, tape recorder, or others, connected to the unit. Defective coupling condenser. 	<p>Replace transistor head amplifier unit.</p> <p>Replace or repair S_{2a2b} and/or S_{2e}, S_{2f}</p> <p>Replace or repair.</p> <p>Replace.</p> <p>Replace C₇ and/or C₈.</p>
C. Weak sound on AUX, PHONO and TAPE.	<ol style="list-style-type: none"> Abnormal voltage in power circuit and other parts. 	<p>Check and repair.</p>
A. Normal voltage at every part but weak sound on AUX	<ol style="list-style-type: none"> Defective fixed resistance. Short-circuit in output transformer. Discharged capacitor. Aged tube. Defective slide switch or selector switch. 	<p>Check R₅₅~R₅₈, R₆₆~R₇₁ and Compound part CRSO1, CRSO2.</p> <p>Check T₁ and T₂.</p> <p>Check C₂₁~C₂₄, C₃₆ and C₃₇ tubular electrolytic capacitor C₂₅, C₂₆, C₄₀, C₄₁.</p> <p>Check V₁~V₉.</p> <p>Replace or repair S_{3a}, S_{3b}, S_{4a}, S_{4b}, S_{6a}~S_{6c}.</p>
B. Normal voltage at every part but weak sound on PHONO and TAPE.	<ol style="list-style-type: none"> Defective selector switch. Abnormal input circuit: loose contact between input terminal and pin-jack; defective shielded wire. Defective record player, tape recorder or others, connected to the unit. Defective coupling condenser. Discharged bypass condenser. 	<p>Replace or repair S_{2a}, S_{2b}, S_{2e}, S_{2f}, S_{3a} and S_{3b}.</p> <p>Replace or repair.</p> <p>Replace</p> <p>Check C₁, C₂, C₅, C₆, C₇, and C₈.</p> <p>Check C₃, C₄, C₉, and C₁₀.</p>

Symptom	Probable Cause	What to Do
A. Distorted sound on AUX.	<ol style="list-style-type: none"> 1. Aged tube. 2. Short-circuit in output transformer. 3. Defective loudspeaker. 4. Defective record player, adaptor or others, connected to the unit. 	<p>Check $V_1 \sim V_9$.</p> <p>Check and repair T_2 and T_3</p> <p>Replace.</p> <p>Replace</p>
B. Distorted sound on PHONO and TAPE.	<ol style="list-style-type: none"> 1. Defective record player, tape recorder or others, connected to the unit. 2. Defective tubular electrolytic capacitor. 3. Disconnection at fixed resistance. 	<p>Replace.</p> <p>Replace C_1 and/or C_2.</p> <p>Check $R_{27} \sim R_{32}$, R_4, R_{13}, R_{14}, R_{15}, R_{16}, R_{17}, R_{18}, R_{19}, R_{20}, R_{21} and R_{22}.</p>
A. Hum on AUX.	<ol style="list-style-type: none"> 1. Electrolytic capacitor discharged. 2. Defective tube. 3. Defective record player, adaptor or others, connected to the unit. 4. Hum balancer not properly adjusted. 5. Disconnected NF resistor. 	<p>Check C_{35}, $C_{66} \sim C_{73}$, $C_{76} \sim C_{77}$.</p> <p>Check $V_1 \sim V_9$.</p> <p>Replace.</p> <p>Check VR_{14} and VR_{15}.</p> <p>Check R_{32} and R_{33}.</p>
B. Hum on PHONO and TAPE.	<ol style="list-style-type: none"> 1. Defective shielded wire and/or wrong connection of record player, tape recorder or others. 2. Audio system and shielded wire induced from outside. 3. Residual hum of audio system connected to the unit. 	<p>Replace and connect correctly</p> <p>Keep proper distance between audio system and inductor.</p> <p>Replace or repair.</p>
A. Noise on AUX and TUNER.	<ol style="list-style-type: none"> 1. Fixed resistor badly connected or touched by another part. 2. Capacitor nearly short-circuited or touched by another part. 3. Primary coil of output transformer nearly disconnected. 4. Defective tube. 	<p>Check R_{37}, R_{38}, R_{41}, R_{42}, R_{63}, R_{64}, R_{34}, R_{85}, R_{86}, R_{37}, R_{92}, R_{93}, R_{95}, and R_{96}.</p> <p>Check C_{56}, C_{57}, C_{60}, C_{61}.</p> <p>Check T_2 and T_3.</p> <p>Check $V_1 \sim V_9$.</p>
B. Noise on PHONO and TAPE.	<ol style="list-style-type: none"> 1. Fixed resistor defective or nearly disconnected. 2. Defective capacitor. 3. Noise or bad connection of audio system connected to the unit. 	<p>Check $R_7 \sim R_{32}$</p> <p>Check $C_1 \sim C_{10}$</p> <p>Replace or repair</p>

PARTS LIST

Part No.	Nomenclature
R1	5K Ω 1/4 Watt \pm 10% Carbon Fixed Resistor
R2	5K Ω 1/4 Watt \pm 10% Carbon Fixed Resistor
R3	100K Ω 1/4 Watt \pm 10% Carbon Fixed Resistor
R4	100K Ω 1/4 Watt \pm 10% Carbon Fixed Resistor
R5	150K Ω 1/4 Watt \pm 10% Carbon Fixed Resistor
R6	150K Ω 1/4 Watt \pm 10% Carbon Fixed Resistor
R7	170K Ω 1/4 Watt \pm 10% Carbon Fixed Resistor
R8	170K Ω 1/4 Watt \pm 10% Noise-Less Resistor
R9	100K Ω 1/4 Watt \pm 10% Noise-Less Resistor
R10	100K Ω 1/4 Watt \pm 10% Noise-Less Resistor
R11	15K Ω 1/4 Watt \pm 10% Noise-Less Resistor
R12	15K Ω 1/4 Watt \pm 10% Noise-Less Resistor
R13	300 Ω 1/4 Watt \pm 10% Carbon Fixed Resistor
R14	300 Ω 1/4 Watt \pm 10% Carbon Fixed Resistor
R15	15K Ω 1/4 Watt \pm 10% Noise-Less Resistor
R16	15K Ω 1/4 Watt \pm 10% Noise-Less Resistor
R17	70K Ω 1/4 Watt \pm 10% Noise-Less Resistor
R18	70K Ω 1/4 Watt \pm 10% Noise-Less Resistor
R19	15K Ω 1/4 Watt \pm 10% Noise-Less Resistor
R20	15K Ω 1/4 Watt \pm 10% Noise-Less Resistor
R21	12K Ω 1/4 Watt \pm 10% Noise-Less Resistor
R22	12K Ω 1/4 Watt \pm 10% Noise-Less Resistor
R23	10 Ω 1/4 Watt \pm 10% Carbon Fixed Resistor
R24	10 Ω 1/4 Watt \pm 10% Carbon Fixed Resistor
R25	3K Ω 1/4 Watt \pm 10% Noise-Less Resistor
R26	3K Ω 1/4 Watt \pm 10% Noise-Less Resistor
R27	12K Ω 1/4 Watt \pm 10% Carbon Fixed Resistor
R28	12K Ω 1/4 Watt \pm 10% Carbon Fixed Resistor
R29	16K Ω 1/4 Watt \pm 10% Carbon Fixed Resistor
R30	16K Ω 1/4 Watt \pm 10% Carbon Fixed Resistor
R31	5K Ω 1/4 Watt \pm 10% Carbon Fixed Resistor
R32	5K Ω 1/4 Watt \pm 10% Carbon Fixed Resistor
R33	50K Ω 1/4 Watt \pm 10% Carbon Fixed Resistor
R34	50K Ω 1/4 Watt \pm 10% Carbon Fixed Resistor
R35	2.5K Ω 1/4 Watt \pm 10% Carbon Fixed Resistor
R36	2.5K Ω 1/4 Watt \pm 10% Carbon Fixed Resistor
R37	150K Ω 1/2 Watt \pm 10% Carbon Fixed Resistor
R38	150K Ω 1/2 Watt \pm 10% Carbon Fixed Resistor
R39	100K Ω 1/4 Watt \pm 10% Carbon Fixed Resistor
R40	100K Ω 1/4 Watt \pm 10% Carbon Fixed Resistor
R41	150K Ω 1/2 Watt \pm 10% Carbon Fixed Resistor
R42	150K Ω 1/2 Watt \pm 10% Carbon Fixed Resistor
R43	400K Ω 1/4 Watt \pm 10% Carbon Fixed Resistor
R44	400K Ω 1/4 Watt \pm 10% Carbon Fixed Resistor
R45	1.5K Ω 1/4 Watt \pm 10% Carbon Fixed Resistor
R46	1.5K Ω 1/4 Watt \pm 10% Carbon Fixed Resistor
R47	5M Ω 1/2 Watt \pm 10% Carbon Fixed Resistor
R48	5M Ω 1/2 Watt \pm 10% Carbon Fixed Resistor
R49	100K Ω Enclosed in CRSO2
R50	100K Ω Enclosed in CRSO2

Part No.	Nomenclature
R51	15K Ω Enclosed in CRSO2
R52	15K Ω Enclosed in CRSO2
R53	100K Ω Enclosed in CRSO2
R54	100K Ω Enclosed in CRSO2
R55	50K Ω 1/4 Watt \pm 10% Carbon Fixed Resistor
R56	50K Ω 1/4 Watt \pm 10% Carbon Fixed Resistor
R57	80K Ω 1/4 Watt \pm 10% Carbon Fixed Resistor
R58	80K Ω 1/4 Watt \pm 10% Carbon Fixed Resistor
R59	1.5K Ω 1/4 Watt \pm 10% Carbon Fixed Resistor
R60	1.5K Ω 1/4 Watt \pm 10% Carbon Fixed Resistor
R61	2M Ω 1/4 Watt \pm 10% Carbon Fixed Resistor
R62	2M Ω 1/4 Watt \pm 10% Carbon Fixed Resistor
R63	150K Ω 1/2 Watt \pm 10% Carbon Fixed Resistor
R64	150K Ω 1/2 Watt \pm 10% Carbon Fixed Resistor
R65	20K Ω 1 Watt \pm 10% Carbon Fixed Resistor
R66	2M Ω 1/4 Watt \pm 10% Carbon Fixed Resistor
R67	2M Ω 1/4 Watt \pm 10% Carbon Fixed Resistor
R68	2M Ω 1/4 Watt \pm 10% Carbon Fixed Resistor
R69	2M Ω 1/4 Watt \pm 10% Carbon Fixed Resistor
R70	1M Ω 1/4 Watt \pm 10% Carbon Fixed Resistor
R71	1M Ω 1/4 Watt \pm 10% Carbon Fixed Resistor
R72	50K Ω Enclosed in CRSO1
R73	50K Ω Enclosed in CRSO1
R74	50K Ω Enclosed in CRSO1
R75	50K Ω Enclosed in CRSO1
R76	50K Ω Enclosed in CRSO1
R77	50K Ω Enclosed in CRSO1
R78	300 Ω 1/4 Watt \pm 10% Carbon Fixed Resistor
R79	300 Ω 1/4 Watt \pm 10% Carbon Fixed Resistor
R80	1.5K Ω 1/4 Watt \pm 10% Carbon Fixed Resistor
R81	1.5K Ω 1/4 Watt \pm 10% Carbon Fixed Resistor
R82	2K Ω 1/4 Watt \pm 10% Carbon Fixed Resistor
R83	2K Ω 1/4 Watt \pm 10% Carbon Fixed Resistor
R84	600K Ω 1/2 Watt \pm 10% Carbon Fixed Resistor
R85	600K Ω 1/2 Watt \pm 10% Carbon Fixed Resistor
R86	150K Ω 1/2 Watt \pm 10% Carbon Fixed Resistor
R87	150K Ω 1/2 Watt \pm 10% Carbon Fixed Resistor
R88	12K Ω 1/4 Watt \pm 10% Carbon Fixed Resistor
R89	12K Ω 1/4 Watt \pm 10% Carbon Fixed Resistor
R90	6K Ω 1/4 Watt \pm 10% Carbon Fixed Resistor
R91	6K Ω 1/4 Watt \pm 10% Carbon Fixed Resistor
R92	30K Ω 1/2 Watt \pm 10% Carbon Fixed Resistor
R93	30K Ω 1/2 Watt \pm 10% Carbon Fixed Resistor
R94	50K Ω 1 Watt \pm 10% Carbon Fixed Resistor
R95	30K Ω 1/2 Watt \pm 10% Carbon Fixed Resistor
R96	30K Ω 1/2 Watt \pm 10% Carbon Fixed Resistor
R97	250K Ω 1/4 Watt \pm 10% Carbon Fixed Resistor
R98	250K Ω 1/4 Watt \pm 10% Carbon Fixed Resistor
R99	250K Ω 1/4 Watt \pm 10% Carbon Fixed Resistor
R100	250K Ω 1/4 Watt \pm 10% Carbon Fixed Resistor

Part No.	Nomenclature			
R101	1K Ω	1/4 Watt	$\pm 10\%$	Carbon Fixed Resistor
R102	1K Ω	1/4 Watt	$\pm 10\%$	Carbon Fixed Resistor
R103	1K Ω	1/4 Watt	$\pm 10\%$	Carbon Fixed Resistor
R104	1K Ω	1/4 Watt	$\pm 10\%$	Carbon Fixed Resistor
R105	40K Ω	1/4 Watt	$\pm 10\%$	Carbon Fixed Resistor
R106	40K Ω	1/4 Watt	$\pm 10\%$	Carbon Fixed Resistor
R107	25K Ω	1/4 Watt	$\pm 10\%$	Carbon Fixed Resistor
R108	25K Ω	1/4 Watt	$\pm 10\%$	Carbon Fixed Resistor
R109	50K Ω	1/4 Watt	$\pm 10\%$	Carbon Fixed Resistor
R110	50K Ω	1/4 Watt	$\pm 10\%$	Carbon Fixed Resistor
R111	16 Ω	10Watt	$\pm 10\%$	Wire Wound Resistor
R112	16 Ω	10Watt	$\pm 10\%$	Wire Wound Resistor
R113	30 Ω	1 Watt	$\pm 10\%$	Carbon Fixed Resistor
R114	30 Ω	1 Watt	$\pm 10\%$	Carbon Fixed Resistor
R115	2.5K Ω	1/4 Watt	$\pm 10\%$	Carbon Fixed Resistor
R116	2.5K Ω	1/4 Watt	$\pm 10\%$	Carbon Fixed Resistor
R117	5K Ω	1/4 Watt	$\pm 10\%$	Carbon Fixed Resistor
R118	150K Ω	1 Watt	$\pm 10\%$	Carbon Fixed Resistor
R119	15K Ω	1/2 Watt	$\pm 10\%$	Carbon Fixed Resistor
R120	4K Ω	2 Watt	$\pm 10\%$	Carbon Fixed Resistor
R121	2K Ω	10Watt	$\pm 10\%$	Wire Wound Resistor
R122	12K Ω	20Watt	$\pm 10\%$	Wire Wound Resistor
R123	2k Ω	1/4 Watt	$\pm 10\%$	Carbon Fixed Resistor
R124	500 Ω	1/4 Watt	$\pm 10\%$	Carbon Fixed Resistor
R125	7K Ω	1/4 Watt	$\pm 10\%$	Carbon Fixed Resistor
R126	7K Ω	1/4 Watt	$\pm 10\%$	Carbon Fixed Resistor
R127	7K Ω	1/4 Watt	$\pm 10\%$	Carbon Fixed Resistor
R128	7K Ω	1/4 Watt	$\pm 10\%$	Carbon Fixed Resistor
R129	6K Ω	1/4 Watt	$\pm 10\%$	Carbon Fixed Resistor
R130	2K Ω	1/4 Watt	$\pm 10\%$	Carbon Fixed Resistor
C1	30 μ F	10WV		Electrolytic tubular
C2	30 μ F	10WV		Electrolytic tubular
C3	30 μ F	10WV		Electrolytic tubular
C4	30 μ F	10WV		Electrolytic tubular
C5	30 μ F	12WV		Electrolytic tubular
C6	30 μ F	12WV		Electrolytic tubular
C7	10 μ F	10WV		Electrolytic tubular
C8	10 μ F	10WV		Electrolytic tubular
C9	30 μ F	10WV		Electrolytic tubular
C10	30 μ F	10WV		Electrolytic tubular
C11	0.06 μ F	50WV	$\pm 10\%$	mylar tubular
C12	0.06 μ F	50WV	$\pm 10\%$	mylar tubular
C13	0.025 μ F	50WV	$\pm 10\%$	mylar tubular
C14	0.025 μ F	50WV	$\pm 10\%$	mylar tubular
C15	0.01 μ F	50WV	$\pm 10\%$	mylar tubular
C16	0.01 μ F	50WV	$\pm 10\%$	mylar tubular
C17	150pF	500WV	$\pm 10\%$	mica tubular
C18	150pF	500WV	$\pm 10\%$	mica tubular
C19	0.01 μ F	50WV	$\pm 10\%$	mylar tubular

Part No.	Nomenclature			
C20	0.01 μ F	50WV	$\pm 10\%$	mylar tubular
C21	0.003 μ F	400WV	$\pm 10\%$	oil tubular
C22	0.003 μ F	400WV	$\pm 10\%$	oil tubular
C23	0.1 μ F	250WV	$\pm 10\%$	MP tubular
C24	0.1 μ F	250WV	$\pm 10\%$	MP tubular
C25	4 μ F	20WV		Electrolytic tubular
C26	4 μ F	20WV		Electrolytic tubular
C27	0.001 μ F	400WV	$\pm 10\%$	oil tubular
C28	0.001 μ F	400WV	$\pm 10\%$	oil tubular
C29	150pF	Enclosed	in CRSO2	
C30	150pF	Enclosed	in CRSO2	
C31	0.003 μ F	Enclosed	in CRSO2	
C32	0.003 μ F	Enclosed	in CRSO2	
C33	0.03 μ F	Enclosed	in CRSO2	
C34	0.03 μ F	Enclosed	in CRSO2	
C35	20 μ F	300WV		Electrolytic tubular
C36	0.1 μ F	250WV		MP tubular
C37	0.1 μ F	250WV		MP tubular
C38	30 μ F	6WV		Electrolytic tubular
C39	30 μ F	6WV		Electrolytic tubular
C40	4 μ F	20WV		Electrolytic tubular
C41	4 μ F	20WV		Electrolytic tubular
C42	0.005 μ F	400WV		oil tubular
C43	0.005 μ F	400WV		oil tubular
C44	0.005 μ F	400WV		oil tubular
C45	0.005 μ F	400WV		oil tubular
C46	0.01 μ F	400WV	$\pm 10\%$	oil tubular
C47	0.01 μ F	400WV	$\pm 10\%$	oil tubular
C48	300pF	Enclosed	in CRSO1	
C49	300pF	Enclosed	in CRSO1	
C50	200pF	Enclosed	in CRSO1	
C51	200pF	Enclosed	in CRSO1	
C52	200pF	Enclosed	in CRSO1	
C53	200pF	Enclosed	in CRSO1	
C54	30 μ F	6WV		Electrolytic tubular
C55	30 μ F	6WV		Electrolytic tubular
C56	0.2 μ F	250WV	$\pm 10\%$	MP tubular
C57	0.2 μ F	250WV	$\pm 10\%$	MP tubular
C58	0.5 μ F	250WV	$\pm 10\%$	MP tubular
C59	0.5 μ F	250WV	$\pm 10\%$	MP tubular
C60	80pF	500WV	$\pm 10\%$	mica tubular
C61	80pF	500WV	$\pm 10\%$	mica tubular
C62	0.3 μ F	250WV	$\pm 10\%$	MP tubular
C63	0.3 μ F	250WV	$\pm 10\%$	MP tubular
C64	0.3 μ F	250WV	$\pm 10\%$	MP tubular
C65	0.3 μ F	250WV	$\pm 10\%$	MP tubular
C66	20 μ F	300WV		Electrolytic lug terminal
C67	20 μ F	300WV		Electrolytic lug terminal
C68	20 μ F	300WV		Electrolytic lug terminal
C69	20 μ F	300WV		Electrolytic lug terminal

Part No.	Nomenclature				
C20	0.01 μ F	50WV	$\pm 10\%$	mylar	tubular
C21	0.003 μ F	400WV	$\pm 10\%$	oil	tubular
C22	0.003 μ F	400WV	$\pm 10\%$	oil	tubular
C23	0.1 μ F	250WV	$\pm 10\%$	MP	tubular
C24	0.1 μ F	250WV	$\pm 10\%$	MP	tubular
C25	4 μ F	20WV		Electrolytic	tubular
C26	4 μ F	20WV		Electrolytic	tubular
C27	0.001 μ F	400WV	$\pm 10\%$	oil	tubular
C28	0.001 μ F	400WV	$\pm 10\%$	oil	tubular
C29	150pF	Enclosed	in	CRSO2	
C30	150pF	Enclosed	in	CRSO2	
C31	0.003 μ F	Enclosed	in	CRSO2	
C32	0.003 μ F	Enclosed	in	CRSO2	
C33	0.03 μ F	Enclosed	in	CRSO2	
C34	0.03 μ F	Enclosed	in	CRSO2	
C35	20 μ F	300WV		Electrolytic	tubular
C36	0.1 μ F	250WV		MP	tubular
C37	0.1 μ F	250WV		MP	tubular
C38	30 μ F	6WV		Electrolytic	tubular
C39	30 μ F	6WV		Electrolytic	tubular
C40	4 μ F	20WV		Electrolytic	tubular
C41	4 μ F	20WV		Electrolytic	tubular
C42	0.005 μ F	400WV		oil	tubular
C43	0.005 μ F	400WV		oil	tubular
C44	0.005 μ F	400WV		oil	tubular
C45	0.005 μ F	400WV		oil	tubular
C46	0.01 μ F	400WV	$\pm 10\%$	oil	tubular
C47	0.01 μ F	400WV	$\pm 10\%$	oil	tubular
C48	300pF	Enclosed	in	CRSO1	
C49	300pF	Enclosed	in	CRSO1	
C50	200pF	Enclosed	in	CRSO1	
C51	200pF	Enclosed	in	CRSO1	
C52	200pF	Enclosed	in	CRSO1	
C53	200pF	Enclosed	in	CRSO1	
C54	30 μ F	6WV		Electrolytic	tubular
C55	30 μ F	6WV		Electrolytic	tubular
C56	0.2 μ F	250WV	$\pm 10\%$	MP	tubular
C57	0.2 μ F	250WV	$\pm 10\%$	MP	tubular
C58	0.5 μ F	250WV	$\pm 10\%$	MP	tubular
C59	0.5 μ F	250WV	$\pm 10\%$	MP	tubular
C60	80pF	500WV	$\pm 10\%$	mica	tubular
C61	80pF	500WV	$\pm 10\%$	mica	tubular
C62	0.3 μ F	250WV	$\pm 10\%$	MP	tubular
C63	0.3 μ F	250WV	$\pm 10\%$	MP	tubular
C64	0.3 μ F	250WV	$\pm 10\%$	MP	tubular
C65	0.3 μ F	250WV	$\pm 10\%$	MP	tubular
C66	20 μ F	300WV		Electrolytic	lug terminal
C67	20 μ F	300WV		Electrolytic	lug terminal
C68	20 μ F	300WV		Electrolytic	lug terminal
C69	20 μ F	300WV		Electrolytic	lug terminal

Part No.	Nomenclature				
C70	40 μ F	500WV		Electrolytic	lug terminal
C71	40 μ F	500WV		Electrolytic	lug terminal
C72	200 μ F	300WV		Electrolytic	lug terminal
C73	200 μ F	300WV		Electrolytic	lug terminal
C74	0.005 μ F	600WV	$\pm 10\%$	oil	tubular
C75	0.005 μ F	600WV	$\pm 10\%$	oil	tubular
C76	50 μ F	50WV		Electrolytic	tubular
C77	50 μ F	25WV		Electrolytic	tubular
C78	200 μ F	25WV		Electrolytic	tubular
C79	200 μ F	25WV		Electrolytic	tubular
C80	0.005 μ F	500WV	$\pm 100\%$ -0%	Ceramic	tubular
C81	0.05 μ F	400WV	$\pm 10\%$	oil	tubular
VR1 VR2	500K Ω (A) Variable Resistor 24 ϕ type Loudness tap 120K Ω (Volume control)				
VR3~VR6	1M Ω (N) Variable Resistor 24 ϕ type (Tone control)				
VR7 VR8	500K Ω (A.C) Variable Resistor 24 ϕ type (Balance control)				
VR10~13	50K Ω (B) Variable Resistor driver type				
VR14 VR15	100 Ω Hum Balancer driver type				
V1~V3b	12AX7 Pre amplifier				
V4a~V5b	6AN8 Phase splitter				
V6~V9	7189A Power amplifier				
TR1~TR4	Transistor 2SB-381 Head amplifier				
T1	Power transformer				
T2, T3	Output transformer				
SD-1B	Si diode AC (RMS) 280V ID 500mA -60 $^{\circ}$ C~+100 $^{\circ}$ C				
SW-0503	Si diode AC (RMS) 90V ID 500mA -55 $^{\circ}$ C~+100 $^{\circ}$ C				
S1(a~b)	Cartridge switch				
S2(a~f)	Input Selector switch				
S3(a~c)	Mode switch				
S4(a~b)	Tape monitor switch				
S5(a~b)	Loudness switch				
S6(a~d)	Tone defeat switch				
S7(a~d)	Low filter switch				
S8(a~b)	High filter switch				
S9(a~b)	Presence switch				
S10(a~b)	Speaker switch				
S11(a~b)	Level meter control switch				
S12	Power switch				
S13a, 13b	Level meter pilot lamp switch				
S14a, 14b	Level meter switch				
CO1~2	AC outlet				
OA-91	Ge. diode VD=90V ID=25mA -55 $^{\circ}$ ~75 $^{\circ}$ C				

SCHEMATIC DIAGRAM

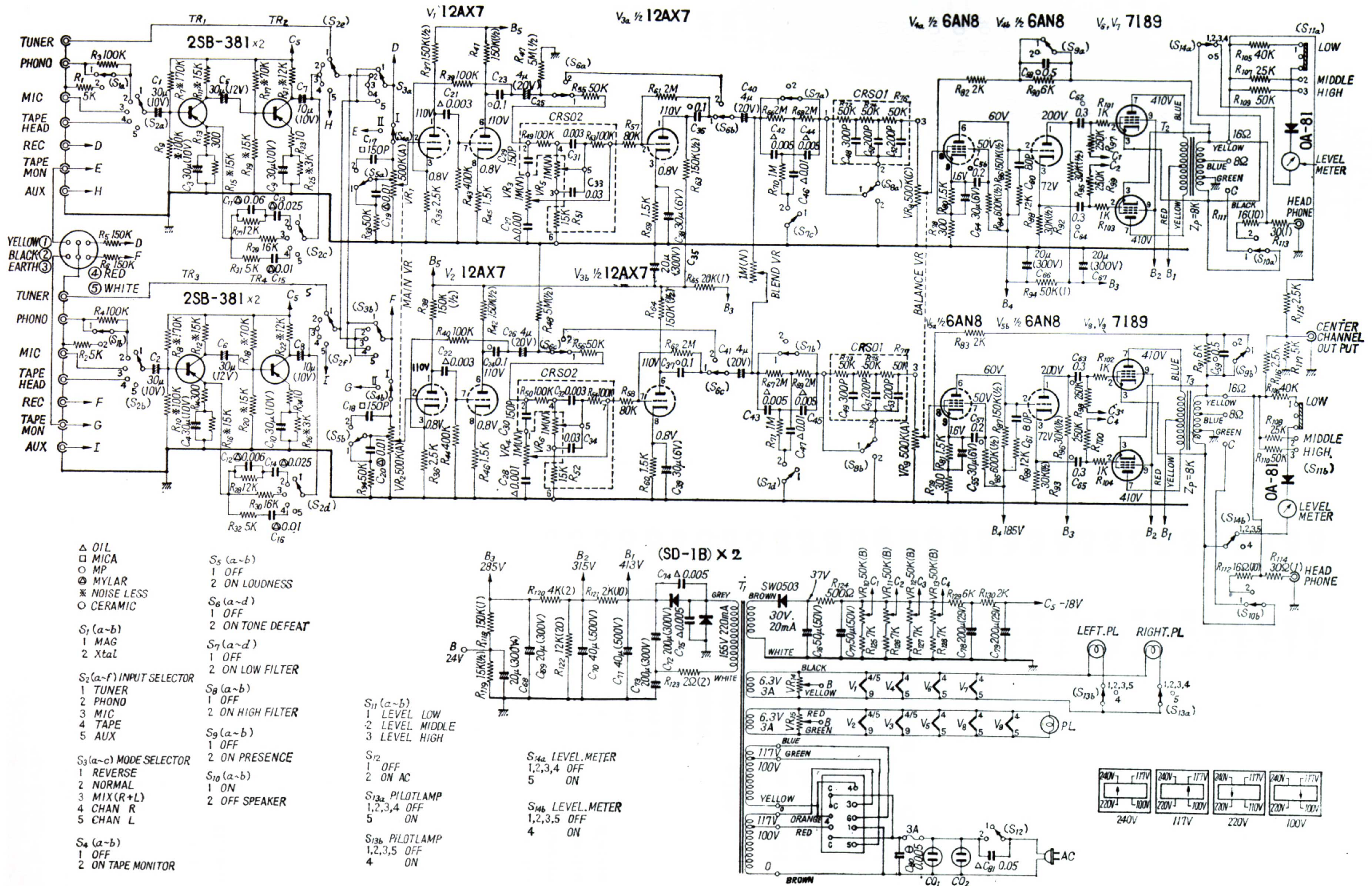

PARTS LAYOUT

